

MULTITURRET BAR TURNING

B446-465 T2

B446-465 T3

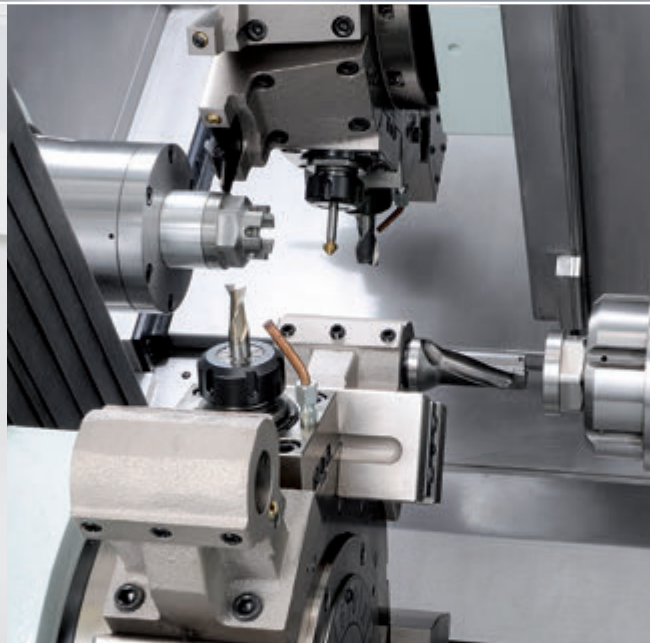

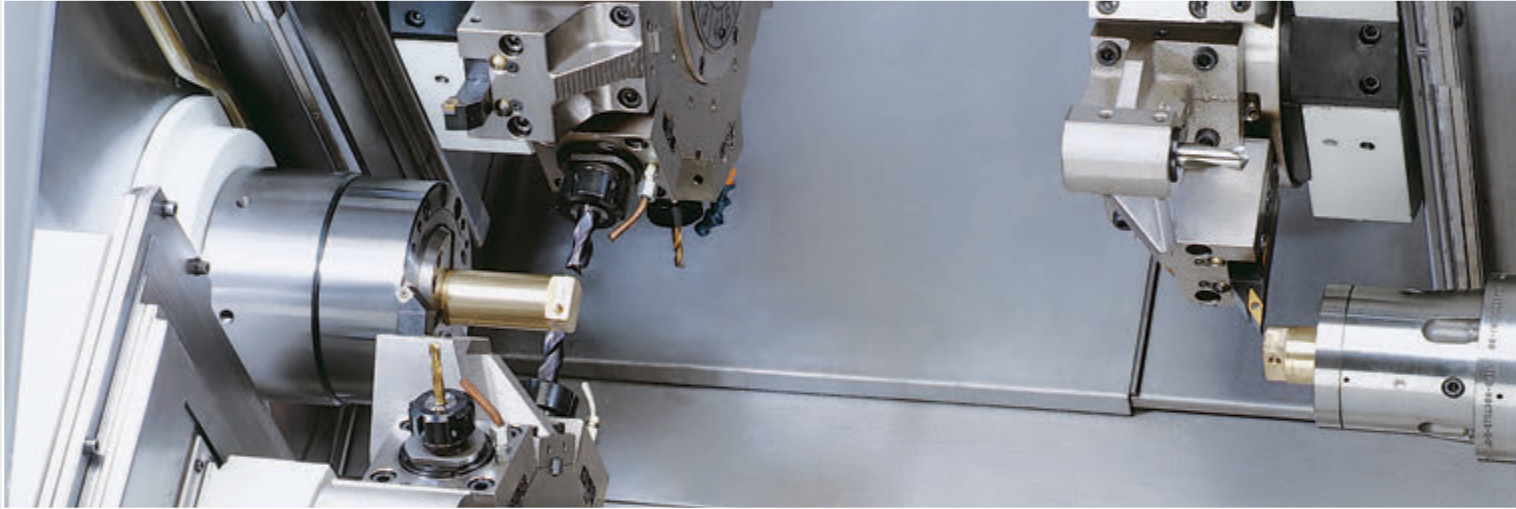
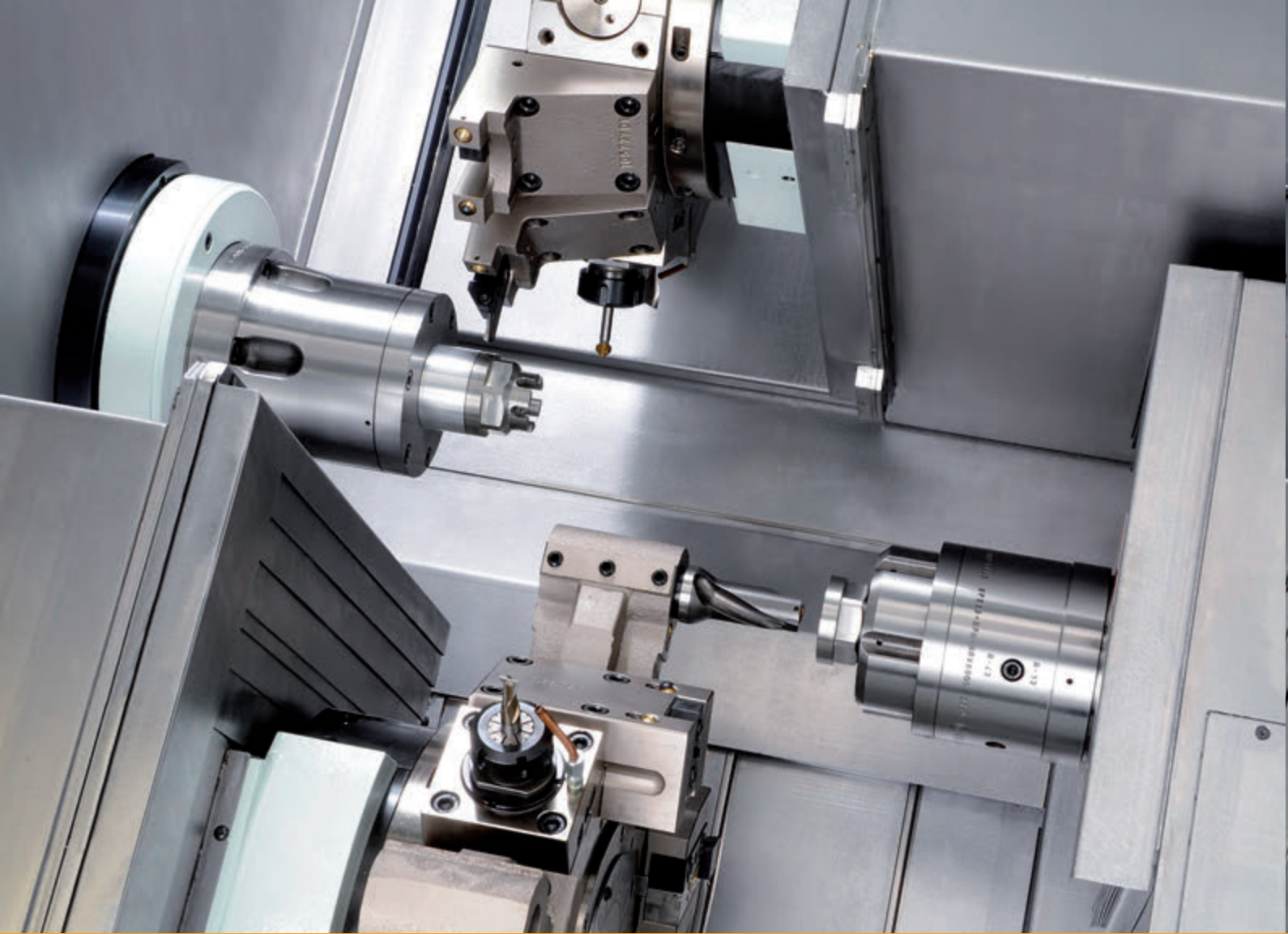

**Double-spindle and double-turret turning centres featuring two Y-axes:
from bar to the finished part**

B446-465 T2

20 years after the launch of the first **QUATTRO** machine, the third generation is now further enhanced by the new range of **QUATTRO T2** turning centres now featuring a longer machine bed and flat guides on the X-axes.

The main performance benefits offered by the robust machine components such as the structure, guides and turrets are:

- Great rigidity allowing to machine harder materials
- Reduction of cycle times and longer tool service life
- Up to 30 tools available for machining of complex parts.





in one set-up

Models available

B446-465 T2 S2M

- 2 turrets equipped with live tooling
- 2 spindles featuring C-axis

B446-465 T2 Y

- 2 turrets equipped with live tooling
- 2 spindles featuring C-axis
- 1 Y-axis

B446-465 T2 Y2

- 2 turrets equipped with live tooling
- 2 spindles featuring C-axis
- 2 Y-axes

The new **QUATTRO**, range of double-spindle and double-turret turning centres for bar machining is available in the T2 and T3 configurations featuring two or three turrets with bar capacity of 51 or 70 mm.



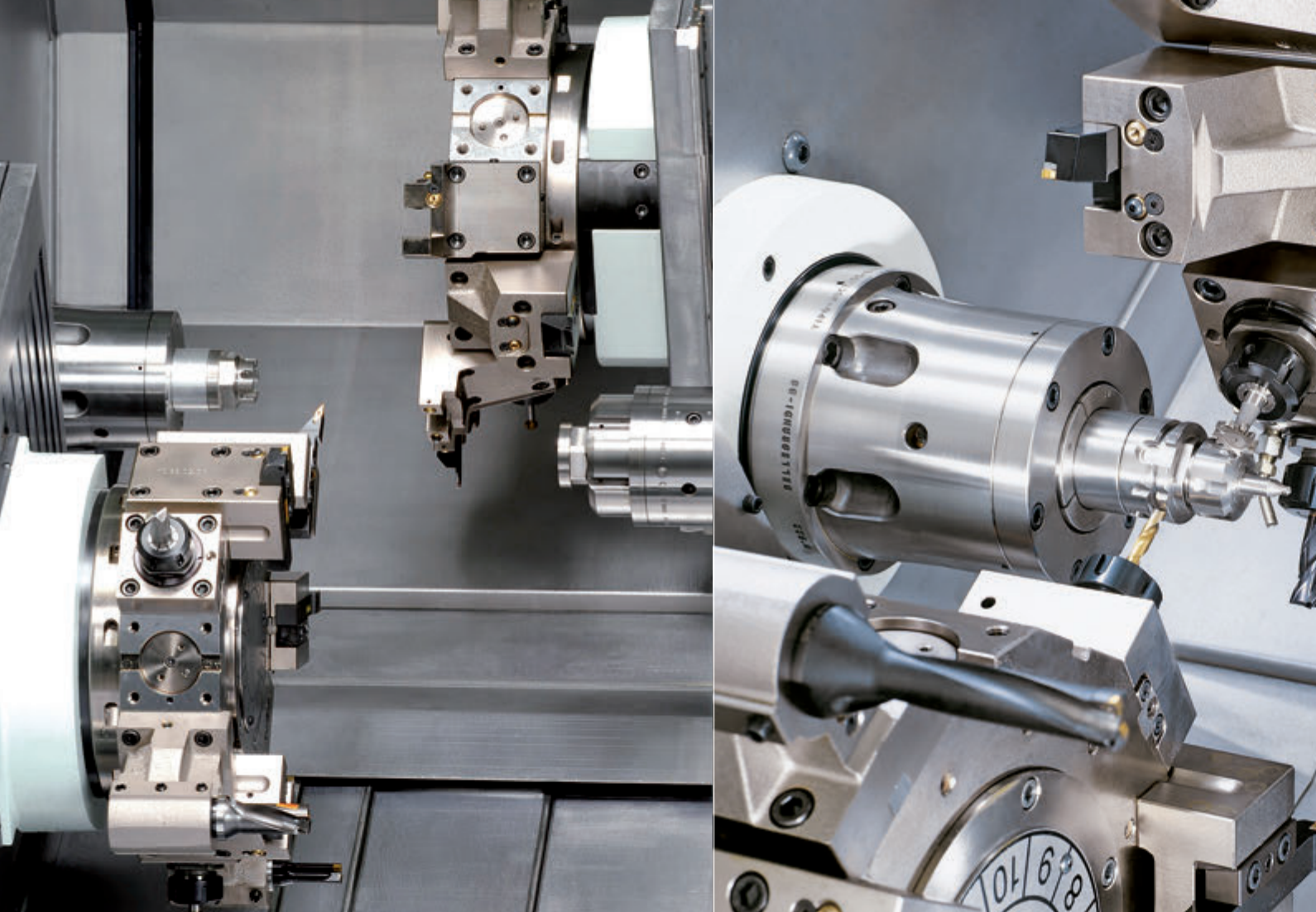

Generous machining area to achieve top-level performance.

- ① Simultaneous machining of T1 on M1 and T2 on the offset M2
- ② Simultaneous machining of T1 and T2 on M1
- ③ Simultaneous machining of T1 and T2 on M1 using M2 as regular tailstock

Legend = M1: main spindle • M2: sub-spindle • T1: upper turret • T2: lower turret

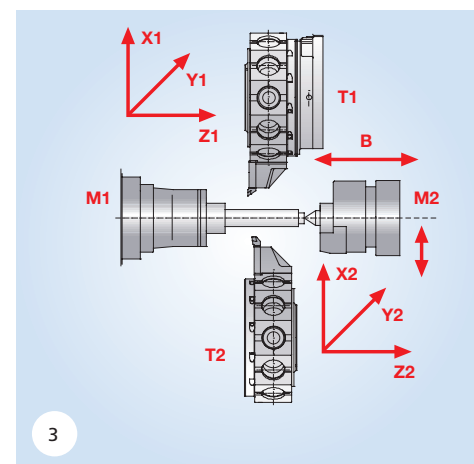
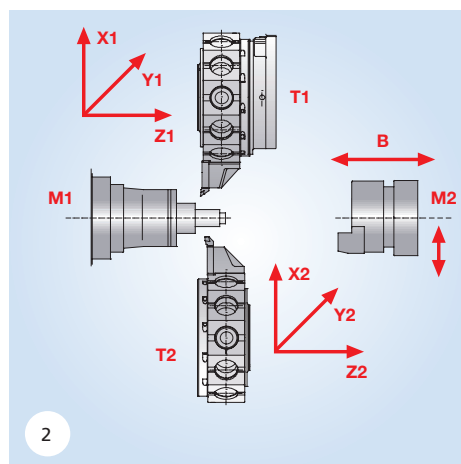
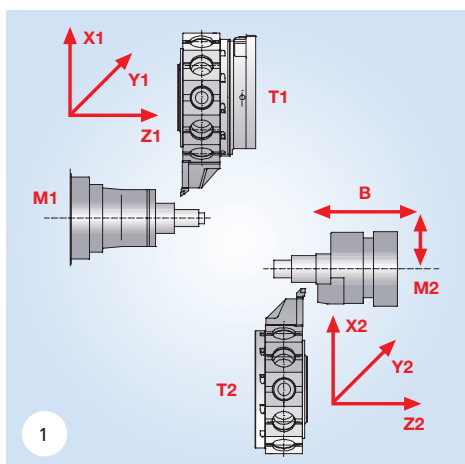

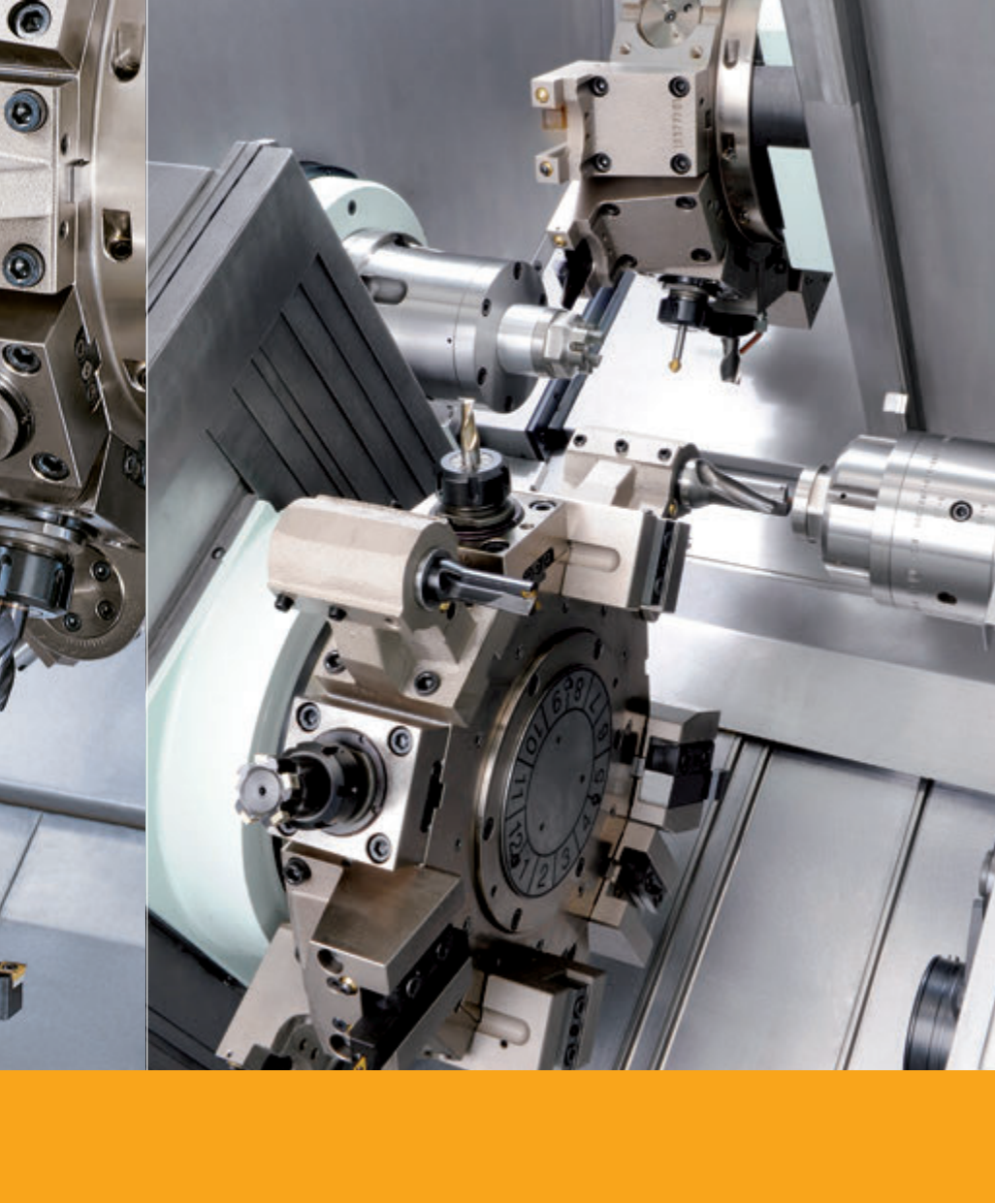

The position of the turrets and the sub-spindle featuring a double movement (longitudinal and transversal) enables reliable and flexible machining operations on both spindles. The main advantages are:

- Automatic and simultaneous machining on both sides of any workpiece
- 4-axis turning using both turrets on main spindle for simultaneous operation
- Parts unloading performed in idle time
- Reduction of non-productive times
- Higher productivity (up to 50%).

The sub-spindle featuring a double movement is offset from the main spindle eliminating interference problems between the two turrets.

- 4 Simultaneous machining of T2 on M1 and T1 on M2. Sub-spindle (M2) coaxial to the main spindle (M1)
- 5 As per picture 2, but with offset M2 to unload the parts in idle time

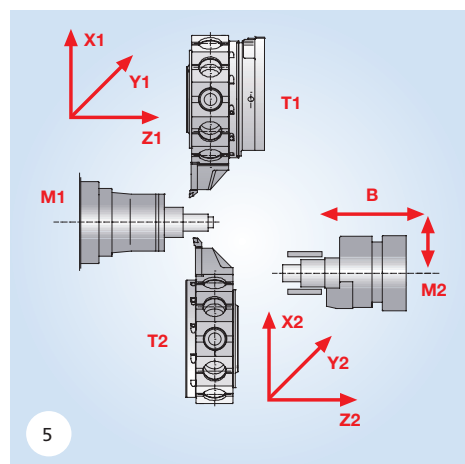
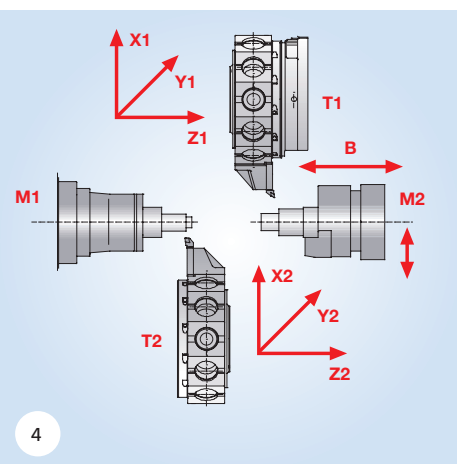

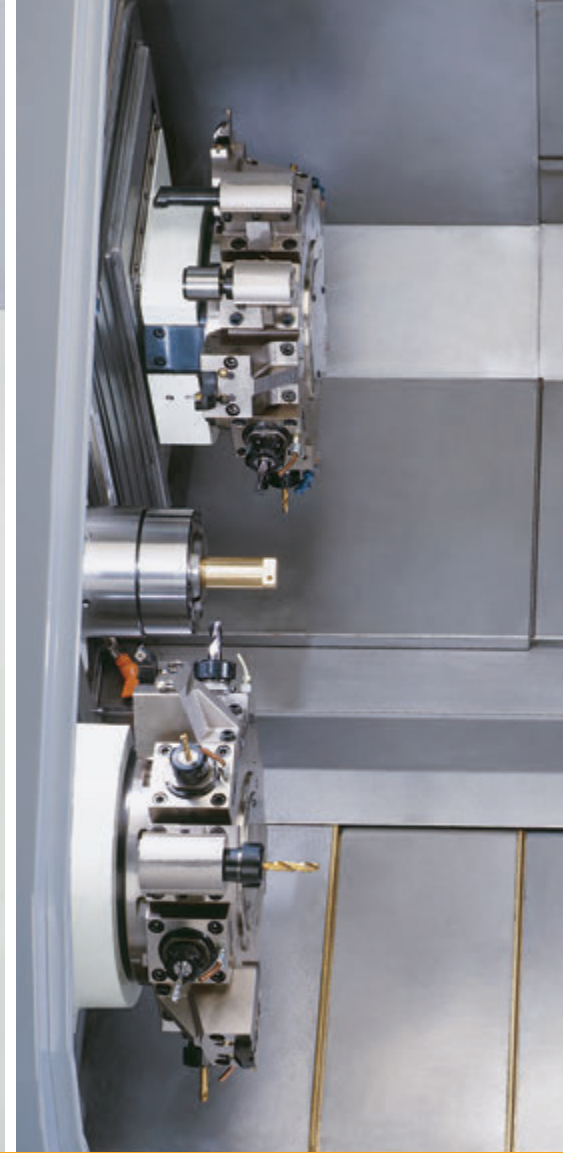
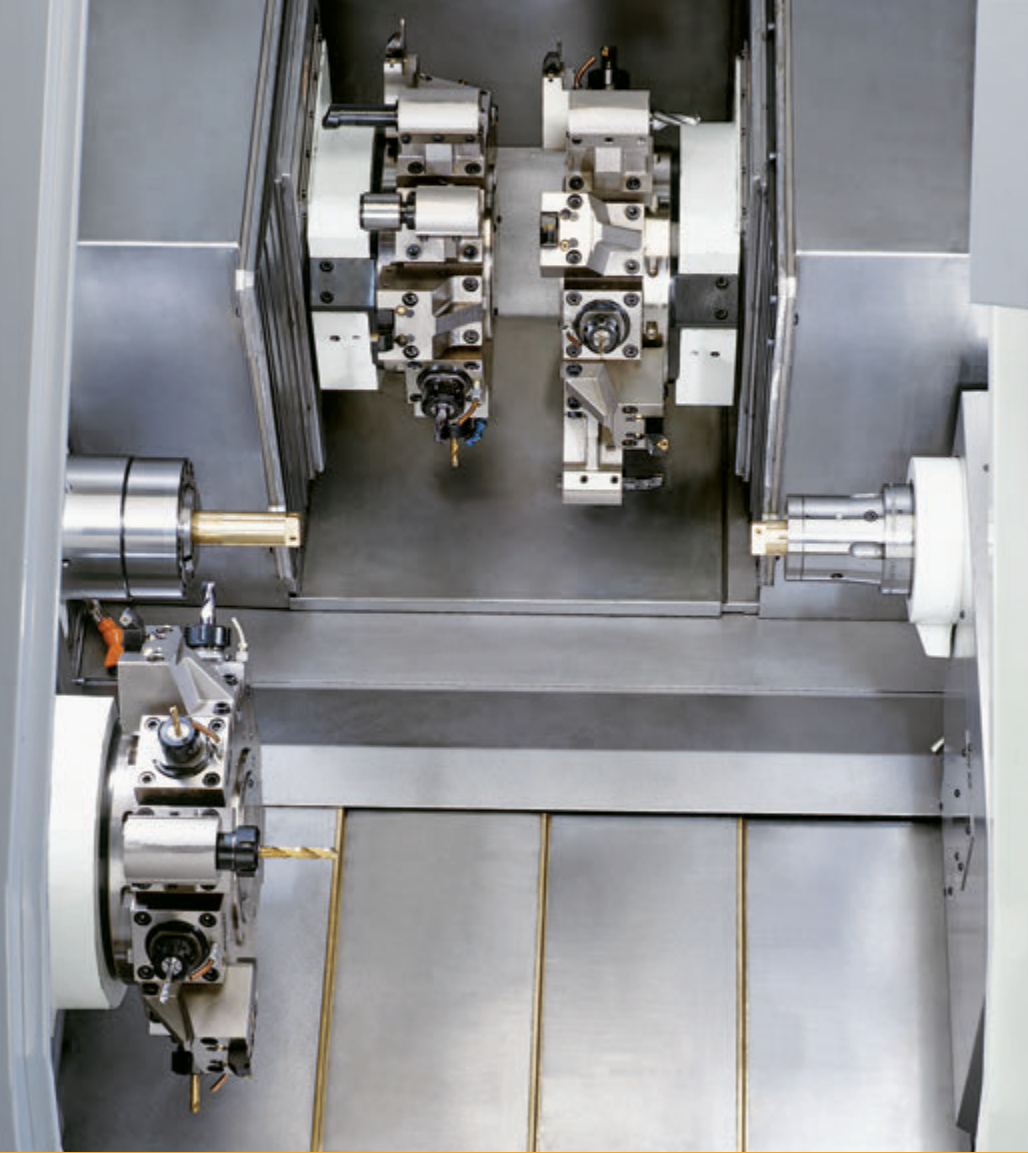

**Double-spindle turning centres featuring three turrets and three Y-axes:
high productivity in machining**

B446-465 T3

The new QUATTRO T3 range of machines equipped with three turrets and thirteen axes is the latest product developed by Biglia in the field of high-performance twin-spindle bar turning centres. The three turrets can perform simultaneous machining using three tools at the same time, thus reducing cycle time dramatically. Thanks to the design of the QUATTRO T3 range of machines, Biglia can achieve new competitive goals in bar machining of complex parts in medium-sized batches. The new QUATTRO T3 range comprises a wide range of alternative specifications and functions to enable flexible machining operations to be completed on a single machining centre.





complex parts from bar.

Models available

446-465 T3 Y2

- 3 turrets equipped with live tooling
- 2 spindles featuring C-axis
- 2 Y-axes

446-465 T3 Y3

- 3 turrets equipped with live tooling
- 2 spindles with C-axis
- 3 Y-axes

The main performance benefits offered by the 30° slant bed and the robust machine components such as the structure, guides and turrets are:

- Great rigidity allowing to machine harder materials
- Reduction of cycle times and longer tool service life
- Up to 50 tools available for machining of complex parts and reduced set-up times
- Ergonomics and easy access for retooling operations
- Perfect removal of chippings





Generous machining area to achieve top-level performance.

- ① Simultaneous machining of T1 and T3 (four axis) on the main spindle and T2 on the sub-spindle
- ② Simultaneous machining of T1 on the main spindle and T2 and T3 (four axis) on the sub-spindle

Legend = M1: main spindle • M2: sub-spindle • T1: upper turret (left) • T2: upper turret (right) • T3: lower turret

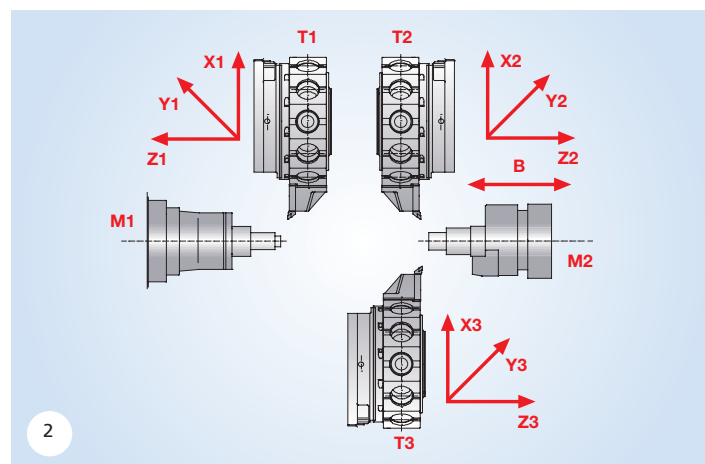
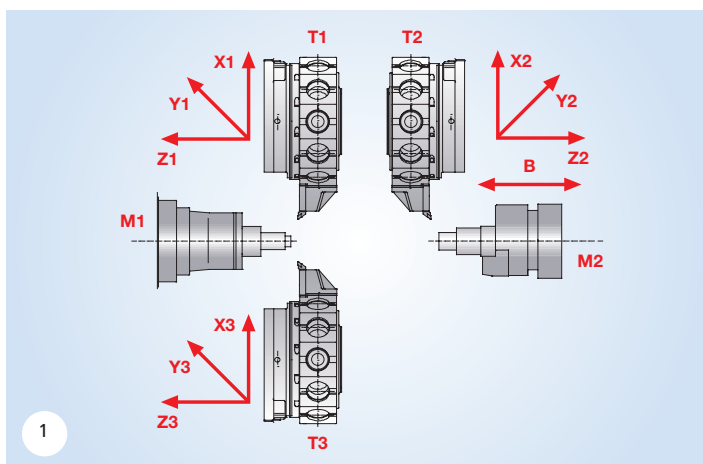

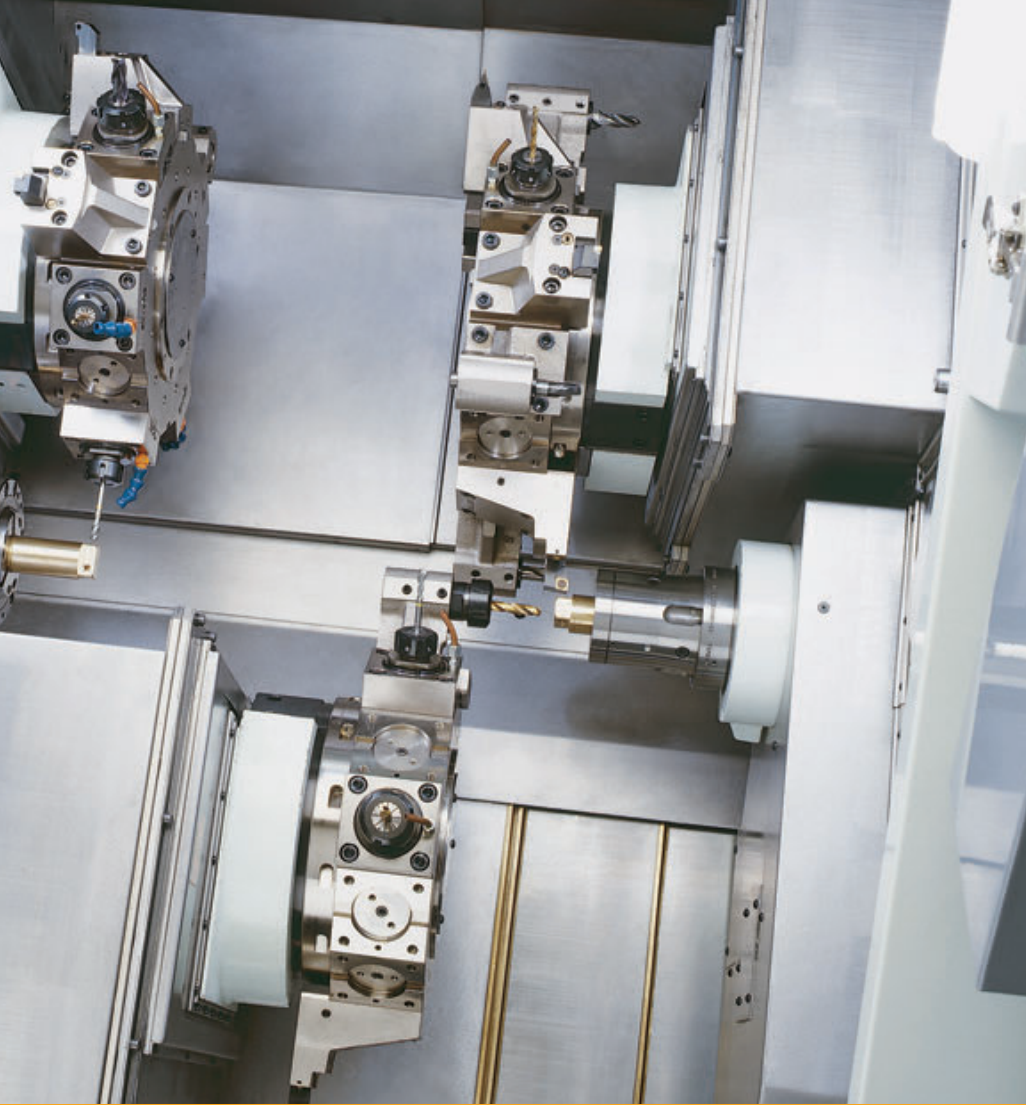

MACHINING CAPABILITY

The position of the three turrets enables reliable and flexible machining operations on both spindles.

The main advantages are:

- Reduction of non-productive times up to 30% if compared to T2 machines
- Automatic and simultaneous machining on both sides of any workpiece
- 4-axis turning using the lower turret on main and sub-spindle for simultaneous operation
- Finished parts unloading is performed in idle time through both spindles.

The combination of 36 live tool stations, 3 Y-axes, 2 C-axes and the possibility to accept more than 50 tools enables the complete machining of complex parts with the highest flexibility.

T3 TOOL-SETTER

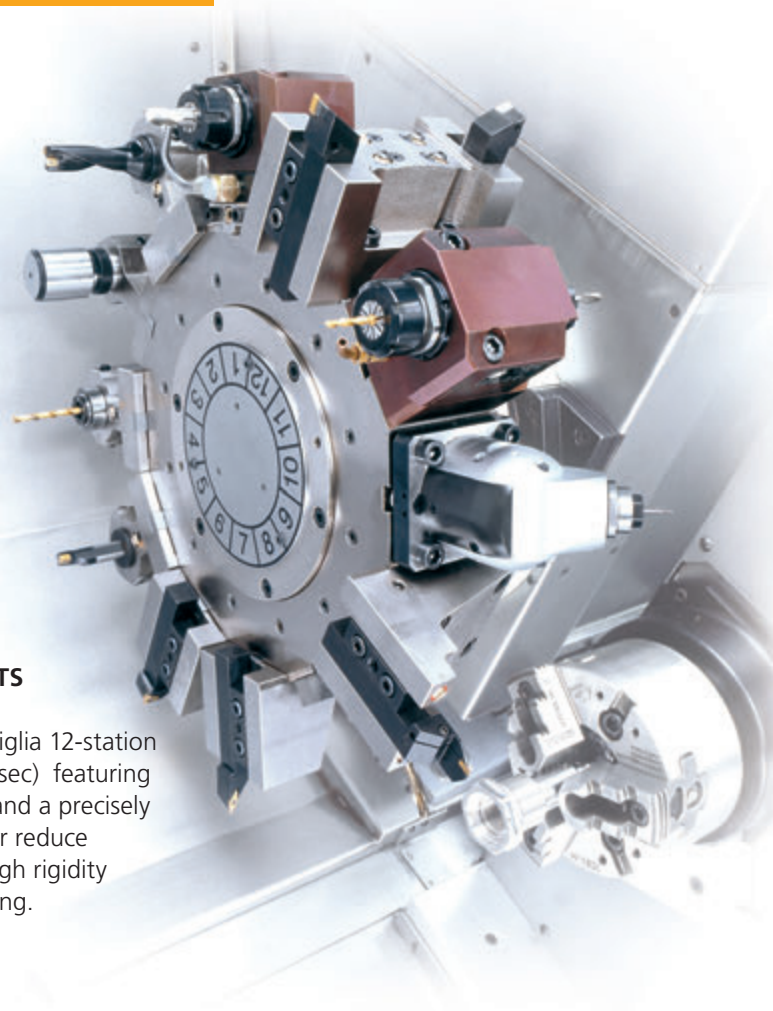
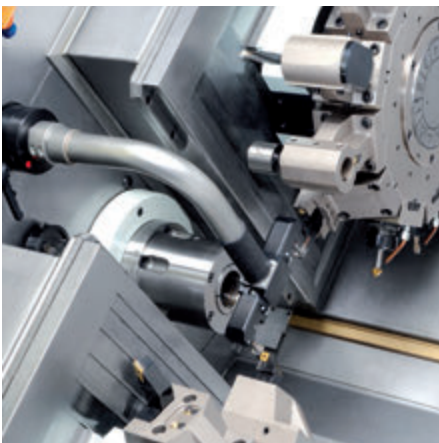

BIGLIA SERVO TURRETS

The rugged and quick Biglia 12-station turrets (index time 0,15 sec) featuring the hydraulic clamping and a precisely dimensioned HIRTH gear reduce idle-times and ensure high rigidity and accuracy in machining.

CAPACITE D'USINAGE

B446-465 T2

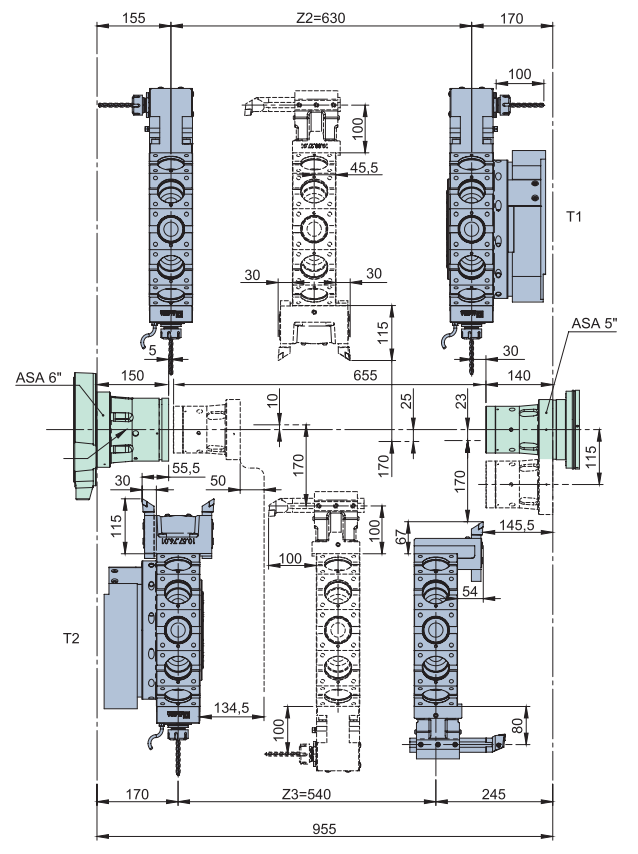
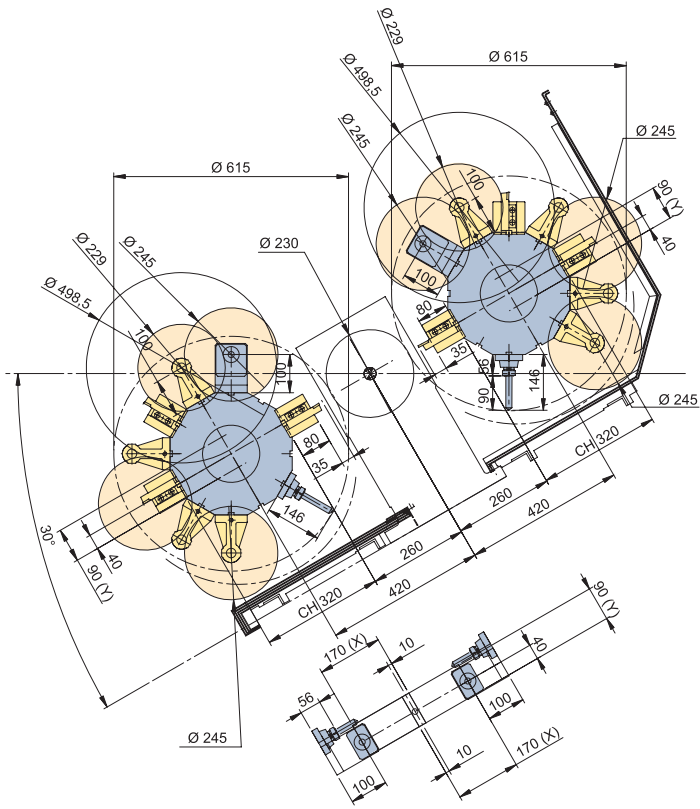

B446-465 T3

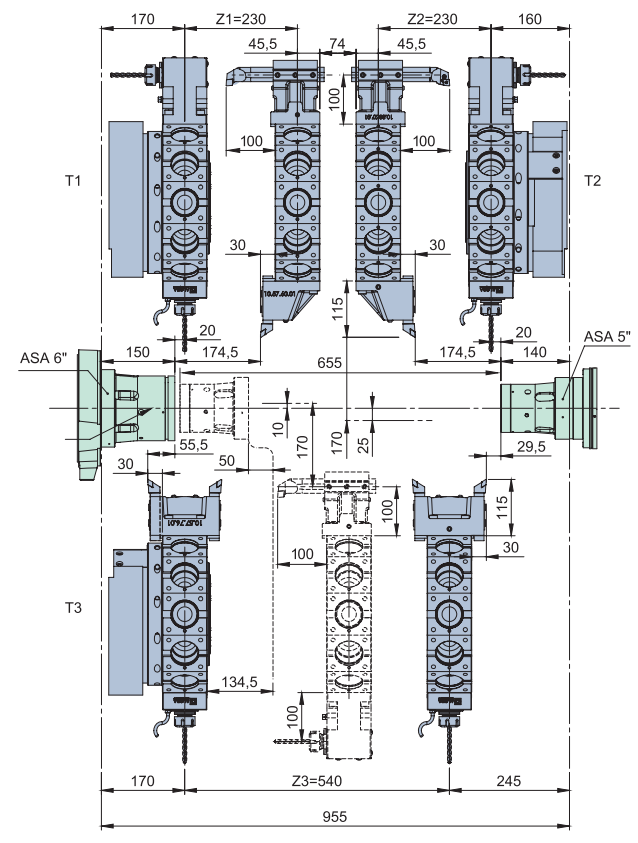
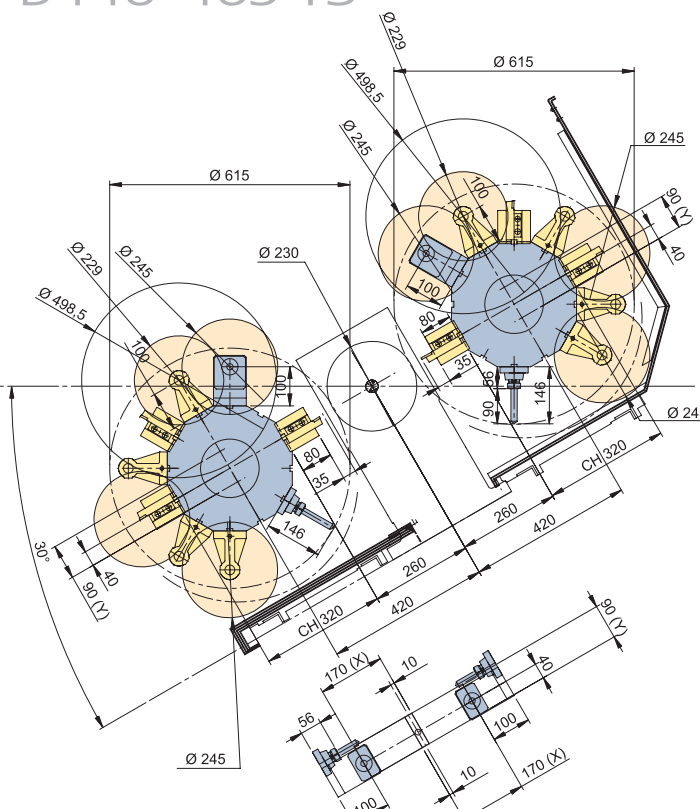

Wide range of equipment and options for T2 and T3 models.

STANDARD FEATURES

- 30° slant cast-iron bed
- 2 or 3 Biglia 12-station servo turrets to suit T2/T3 models
- Sub-spindle equipped with ejector and air blow. Axial movement for the T2 model
- Bar-feeder interface
- Rigid tapping
- CNC programmed automatic parts-catcher
- Finished parts conveyor
- Chip conveyor
- Coolant system featuring 7 bar pumps and filters
- Wash-down system to eliminate chippings
- Two colour alarm lamp
- Electrical cabinet - air conditioned

OPTIONAL MAIN FEATURES

- Tool Probing System
- High-pressure pump (30/40 bar)
- Fume exhauster
- Manual Guide
- Polygon turning
- SBS: Tool Load Monitoring System

PROGRAMMABLE AUTOMATIC PARTS-CATCHER

The automatic parts-catcher may be programmed through M-functions and allows the unloading of finished parts up to 300 mm long in automatic mode or idle time directly on to the parts conveyor.

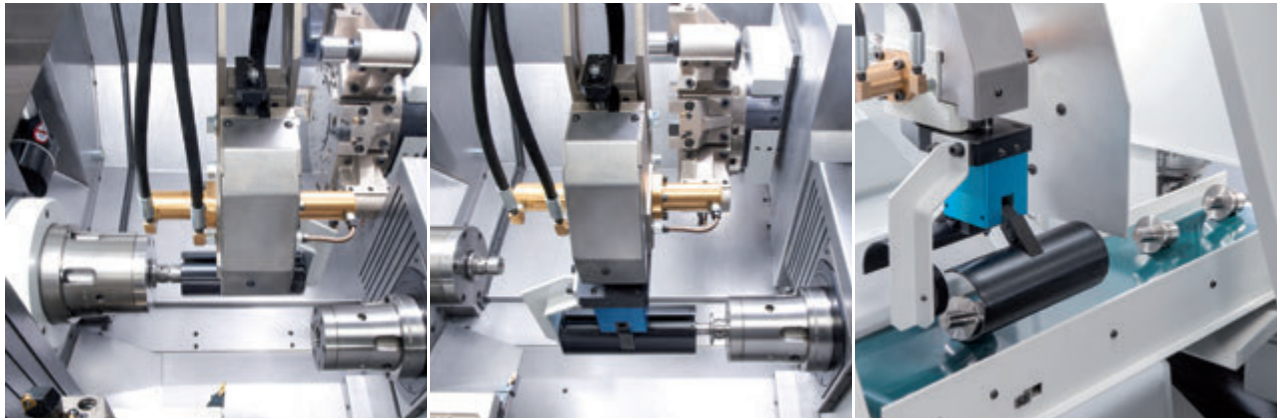

TOOL-SETTER

This device makes tool-setting faster and easier.

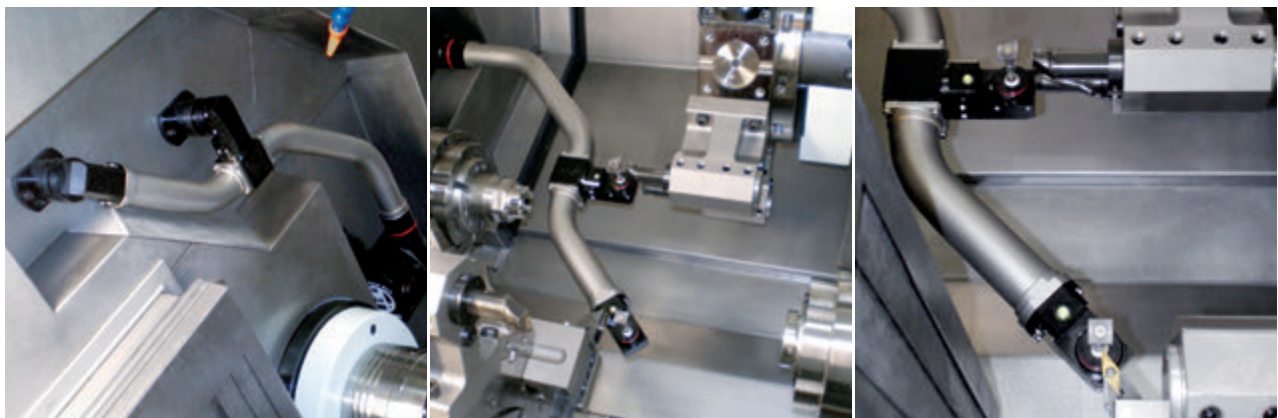

Flexible automation for maximum productivity



INTEGRATED AUTOMATION SYSTEM RBT 2

A machine configuration is available equipped with an integrated loading/unloading automation system featuring 2 CNC axes. The blanks and the machined parts are picked up by two chucks mounted on a wrist that rotates 90° to allow loading/unloading from the machine in a horizontal position and picking up/deposited on a parts handling system in vertical position (NOT supplied).

Twin-spindle/twin-turret turning centre equipped with an integrated automation system. Max diameter: 150 mm; max length: 200 mm; Max weight: 5 kg

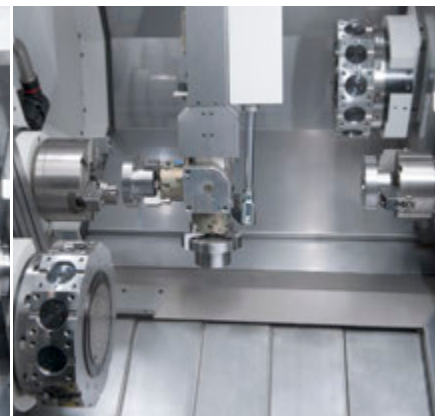
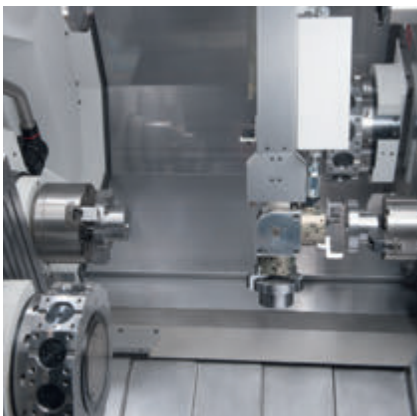
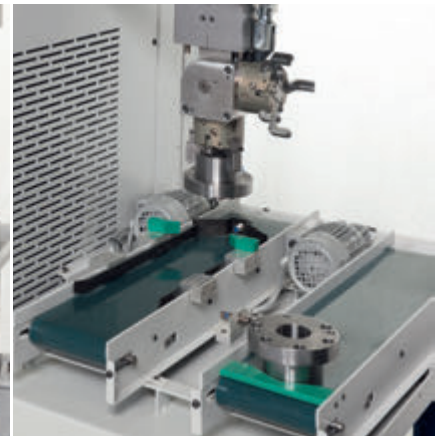



Fanuc CNC unit



**MANUAL GUIDE:
QUICK AND EASY FOR
PROGRAM RELIABILITY**

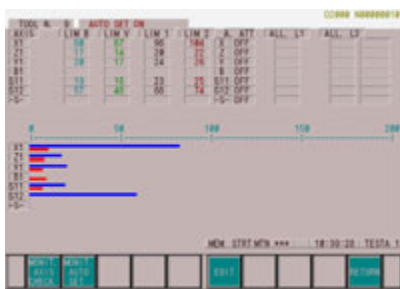

**SBS: BIGLIA SAFETY SOFTWARE
TOOL LOAD MONITORING**

CNC Fanuc 31i-Mod. B:
 - 15" colour liquid crystal display
 - Alphanumeric full-keyboard
 - Biglia operator panel featuring softkeys
 - Data transmission: Ethernet gate, memory card, RS 232 port, USB.

The **MANUAL GUIDE i** software allows the execution of even the most complex programs with ease of operation. The graphical interface offers simple editing functions within a limited number of operations.

Main features

- Advanced cutting cycles (Turning and Milling)
- Capability of resolving complex geometry contours
- Function for tool geometry management
- Cutting of any residual materials in automatic mode
- 3D machining simulation

B446-465 T2

TECHNICAL SPECIFICATIONS

		B446 T2	B465 T2
MACHINING CAPACITY			
Bar capacity	mm	51	70
Max. machining diameter	mm	200	200
Max. machining length	mm	350	350
Max. swing over diameter	mm	220	220
MAIN SPINDLE			
Max. speed	rpm	5000	4000
Spindle nose	ASA	5"	6"
Spindle bore	mm	59,5	78
Inside diameter of bearings	mm	90	110
Chuck diameter	mm	165/210	165/210
Motor power	kW	15 (diagram 2)	26 (diagram 1)
C axis: min. programmable value	°	0,001°	0,001°
SUB-SPINDLE			
Max. speed	rpm	5000	5000
Spindle nose	ASA	5"	5"
Spindle bore	mm	55	55
Drawtube inside diameter	mm	45	45
Inside diameter of bearings	mm	90	90
Chuck diameter	mm	165	165
Motor power (see diagram 3)	kW	11	11
C-axis: min. programmable value	°	0.001°	0,001°
Offset stroke	mm-m	115	115
B-axis: stroke - rapid traverse	mm-m/min	655 - 30	655 - 30
UPPER TURRET 1 - LOWER TORRET 2			
No of tools	N°	12	12
Turret indexing (1 pos)	sec	0,15	0,15
No of live tools	N°	12	12
Max. speed	rpm	4000	4000
Motor power (see diagram 4)	kW	3,7	3,7
X1-X2 axes: stroke - rapid traverse	mm-m/min	170 - 18	170 - 18
Z1-Z2 axes: stroke - rapid traverse	mm-m/min	630-540 - 30	630-540 - 30
Y1-Y2 axes: stroke - rapid traverse	mm-m/min	90 [-40/+50] - 9	90 [-40/+50] - 9
COOLING SYSTEM			
Tank capacity	l	450	450
Motor rating of 3 electropumps	kW	3,7	3,7
DIMENSIONS AND WEIGHT			
Machine with swarf conveyor	mm	5033 x 2100 x 2458 h	
Spindle centre height	mm	1115	1115
Machine weight with swarf conv.	kg	7900	8100

() Option

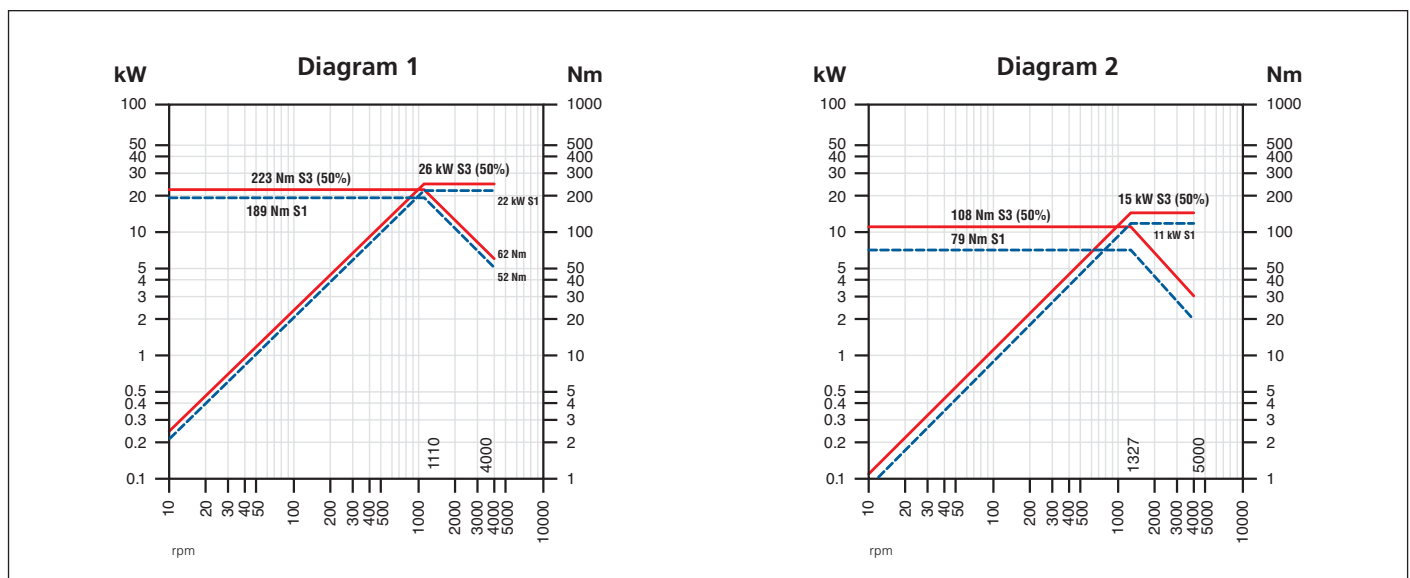

B446-465 T3

TECHNICAL SPECIFICATIONS

		B446 T3	B465 T3
MACHINING CAPACITY			
Max. diam. lavorabile da barra	mm	51	70
Max. diametro lavorabile da ripresa	mm	200	200
Max. lunghezza lavorabile	mm	230	230
Max. diametro rotante	mm	220	220
MAIN SPINDLE			
Max. speed	rpm	5000	4000
Spindle nose	ASA	5"	6"
Spindle bore	mm	59,5	78
Inside diameter of bearings	mm	90	110
Chuck diameter	mm	165/210	165/210
Motor power	kW	15 (diagram 2)	26 (diagram 1)
C axis: min. programmable value	°	0,001°	0,001°
SUB-SPINDLE			
Max. speed	rpm	5000	5000
Spindle nose	ASA	5"	5"
Spindle bore	mm	55	55
Drawtube inside diameter	mm	45	45
Inside diameter of bearings	mm	90	90
Chuck diameter	mm	165	165
Motor power (see diagram 2)	kW	11	11
C-axis: min. programmable value	°	0,001°	0,001°
B-axis: stroke - rapid traverse	mm-m/min	655 - 30	655 - 30
UPPER TURRET (1-left)			
UPPER TURRET (2-right)			
LOWER TURRET 3			
No of tools	N°	12	12
Turret indexing (1 pos)	sec	0,15	0,15
No of live tools	N°	12	12
Max. speed	rpm	4000	4000
Motor power (see diagram 4)	kW	3,7	3,7
X1-X2-X3 axis: stroke - rapid traverse	mm-m/min	170 - 18	170 - 18
Z1-Z2 axis: stroke - rapid traverse	mm-m/min	230 - 30	230 - 30
Z3 axis: stroke - rapid traverse	mm-m/min	540 - 30	540 - 30
Y1-Y2-Y3 axis: stroke - rapid traverse	mm-m/min	90 [-40/+50] - 9	90 [-40/+50] - 9
COOLING SYSTEM			
Tank capacity	l	450	450
Motor rating of 4 electropumps	kW	4,8	4,8
DIMENSIONS AND WEIGHT			
Machine with swarf conveyor	mm	5033 x 2100 x 2458 h	
Spindle centre height	mm	1115	1115
Machine weight with swarf conveyor	kg	8200	8400

() Option

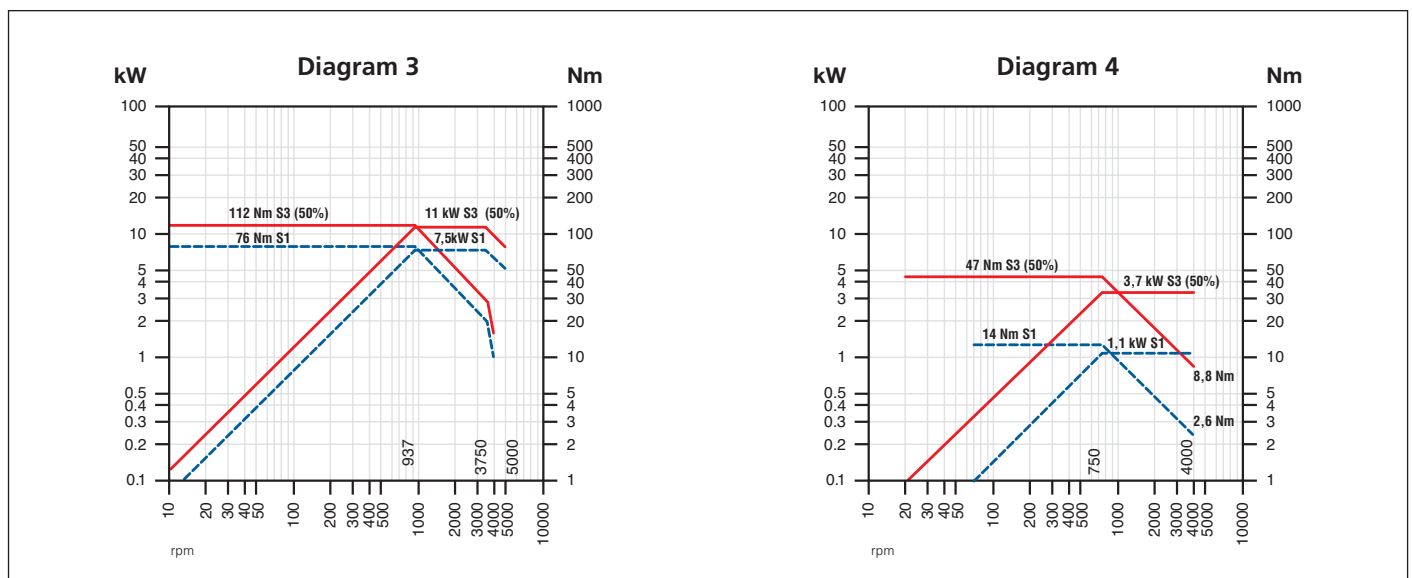

MACHINE DIMENSIONS

B446-465 T2 B446-465 T3

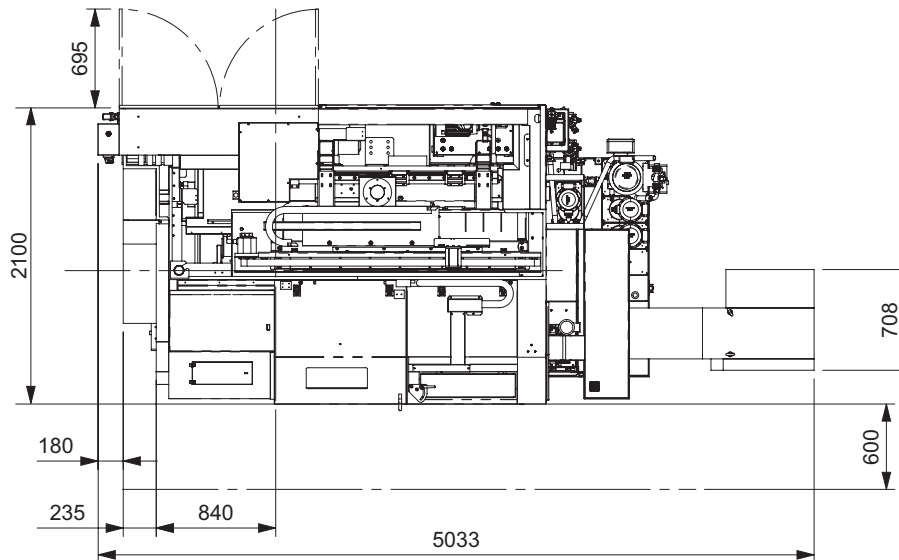
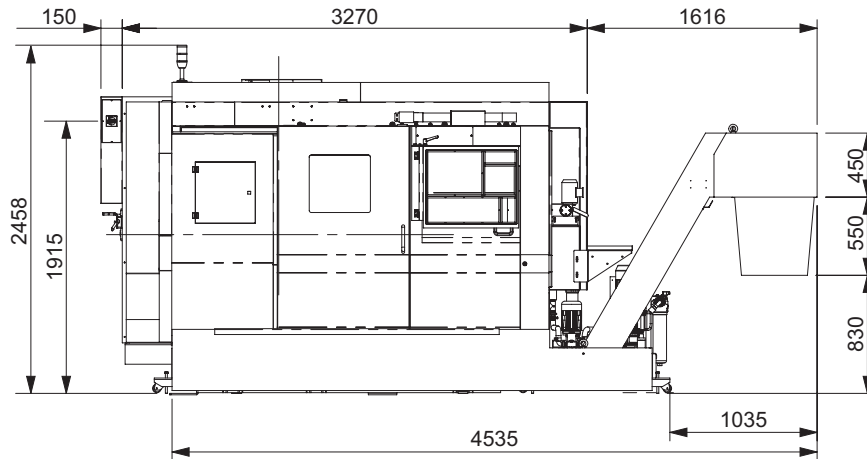

THE TURNING TECH