

EMCO

MMV 2000

**Moving Column
Machining Center**



/ HIGHEST PRECISION IN EVERY DIMENSION

Moving Column Machining Center for 4 or 5 axis machining for small to medium lot sizes. Rapid travel up to 50 m/min with the utmost in precision. The super-structure is highly rigid, even for heavy work pieces weighing up to 2,200 kg.



Drive connector
(Stainless steel)

- 1 TOOL MAGAZINE**
 - / Tool changer with 40 tools
(optional available with other amounts)
- 2 REAR MACHINE COMPARTMENT**
 - / Machine compartment partitioned by maintenance-free steel accordion way-covers
- 3 AXES**
 - / Linear guides in X, Y and Z directions
 - / Linear scales in X, Y and Z directions



Machine with optional equipment

- 4 SPINDLE**
 - / Motor spindle with 15000 rpm
(18000 rpm only for the HSK A63 version)
 - / High dynamic
 - / Water-cooled
- 5 CONTROL**
 - / State-of-the-art control systems
 - / SIEMENS 840D sl
 - / HEIDENHAIN TNC 640
 - / EMCONNECT available for Sinumerik 840D sl
- 6 CHIP CONVEYOR**
 - / Chip conveyor fitted as standard
 - / Chip removal to the right

TECHNICAL HIGHLIGHTS

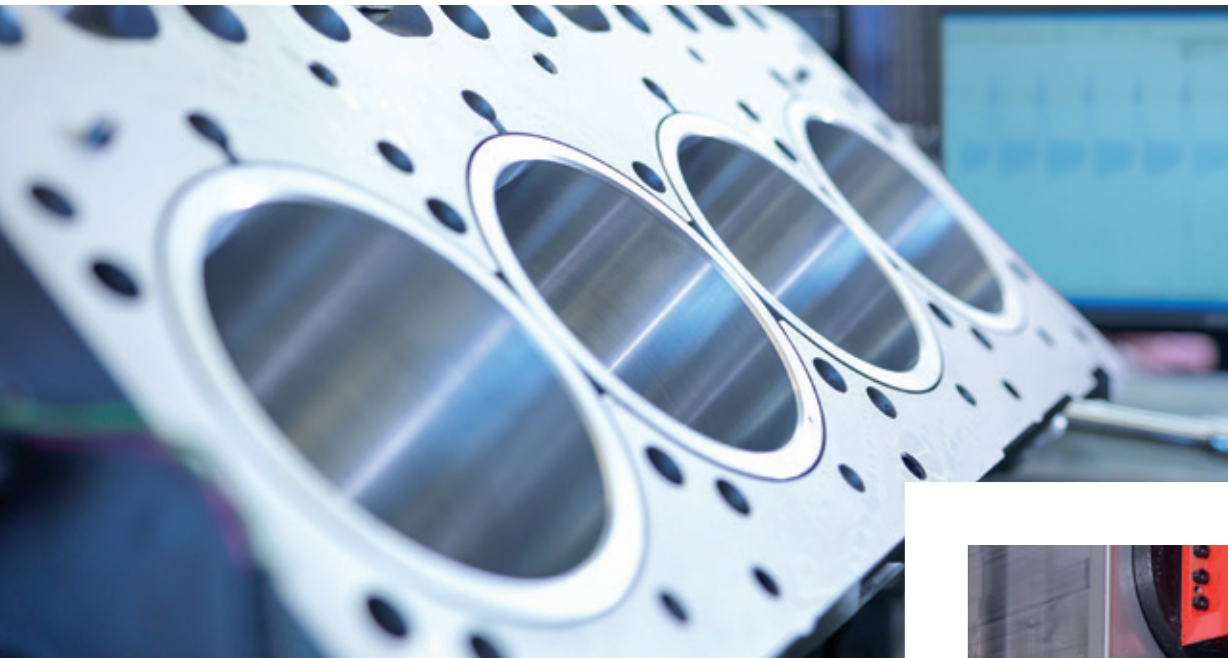

High-performance motor spindle with speed range 0-15000 rpm, power 46 kW and torque 170 Nm, head and C-axis with torque motors and encoders, linear scales in X-, Y-, Z-axis as standard. These are all features that make MMV 2000 the ideal processing center for high quality milling services and enables the complete execution of complex workpieces with excellent surfaces.

APPLICATION AREAS

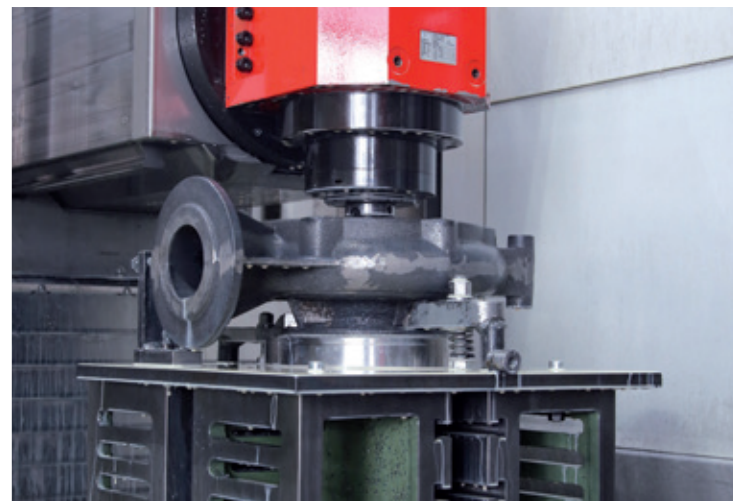

TOOL MAGAZINE

Drum configuration with dual arm grippers for fast tool changes. Random tool management reduces tool changing times to a minimum. Thanks to the lateral magazine door (2x in case of double tool magazine), it is possible to check and set up the tools in parallel with the machining process.



MILLING SPINDLE

The machine is equipped with a liquid cooled motor spindle with compelling performance specs. At spindle speeds of 15000 rpm, a power rating of 46 kW, and max. torque of 170 Nm, the machine is also suited for heavy-duty machining. A motor spindle 18000 rpm is available with HSK-A63.



Y-AXIS

The Y-axis has a ram configuration. This design uses long way guides in order to attain the required rigidity.

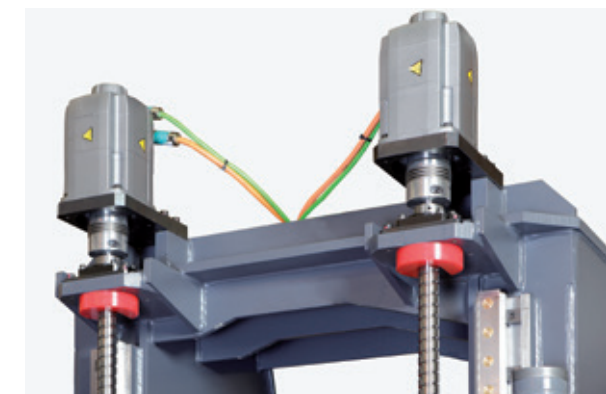

Z-AXIS TRAVEL

In order to attain precision Z-axis rapid travel at speeds of 50 m/min, and due to its large mass, this axis is powered by two ball screw drives and two motors in a master-slave configuration.



CONTROL UNIT

The operator panel can travel and also rotate in the direction of the work space. This ergonomic design provides ideal working conditions for the operator.



B-AXIS

The B-axis is driven by a torque motor, therefore achieving highly dynamic axis travel within the pivoting range of +/- 120 degrees.



MECHANICAL STRUCTURE

The massive structure of the bed based on a steel frame filled with polymer concrete. This ensures the necessary stability of the machine base and also provides optimum vibration damping.

Structure with optional equipment

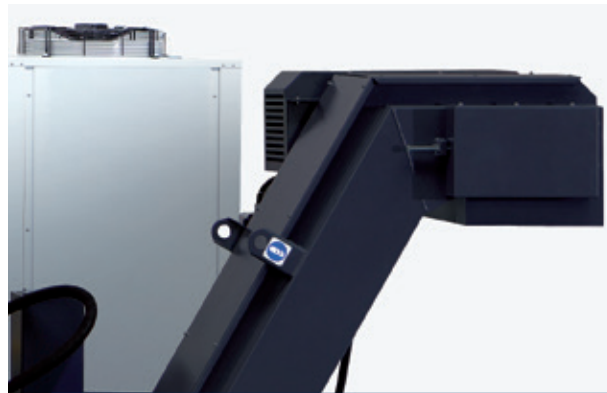

HINGE TYPE CONVEYER

The chip rinsing system washes chips into the hinge type conveyer, which then automatically transports the chips from the machine into the customer provided container.



AXES DRIVES

Linear axes are equipped with linear guides. Long way-guides are used to attain the necessary rigidity. The drive is equipped with a ball screw drive with direct drive bellows coupling. The direct drive provides for highly dynamic axis travel, while also employing a low maintenance and smooth drive system. Linear scales are standard on the three linear axes (X, Y and Z).

HIGHLIGHTS

- / Flexible modular design
- / Available as 4- or 5-axis version
- / High-performance motor spindle
- / Rigid linear way system size 55 (X-axis)
- / Direct driven ball screws on the X- and Z-axis, quiet operation
- / Ideal value for money
- / Rotary table and B-axis with torque motors
- / Pneumatic weight balance, highly dynamic
- / State-of-the-art control systems SIEMENS 840D sl or Heidenhain TNC 640
- / EMCONNECT for Siemens 840D sl
- / Made in the Heart of Europe

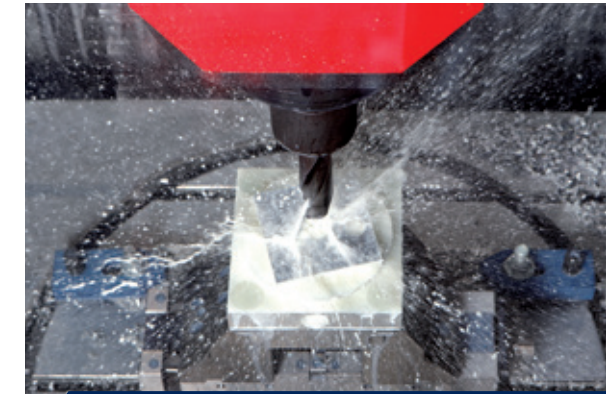

COOLANT THROUGH THE SPINDLE

The spindle can be optionally flooded with high-pressure coolant (25 to 60 bar). This ensures reliable chip removal from holes and pockets and reduces cycle times for this type of machining.

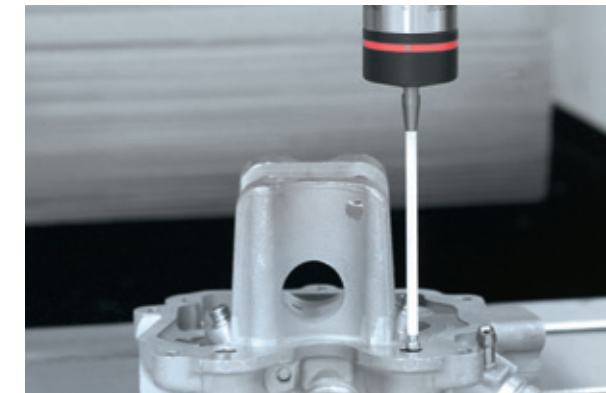

MEASUREMENT SYSTEMS

Tools measurements to reduce setup times during tool changes, as well as workpiece measurements to verify dimensions or to find zero locations. The optional workpiece measurement has a radio transmission, the tool set-up will be done by laser.

OPTIONS

- / Workpiece and tool measurement
- / Coolant through the spindle
- / Automatic doors
- / Hydraulic device for clamping systems
- / Air through the spindle
- / Paper filter systems
- / Pneumatic or hydraulic rotary coupling through the rotary table

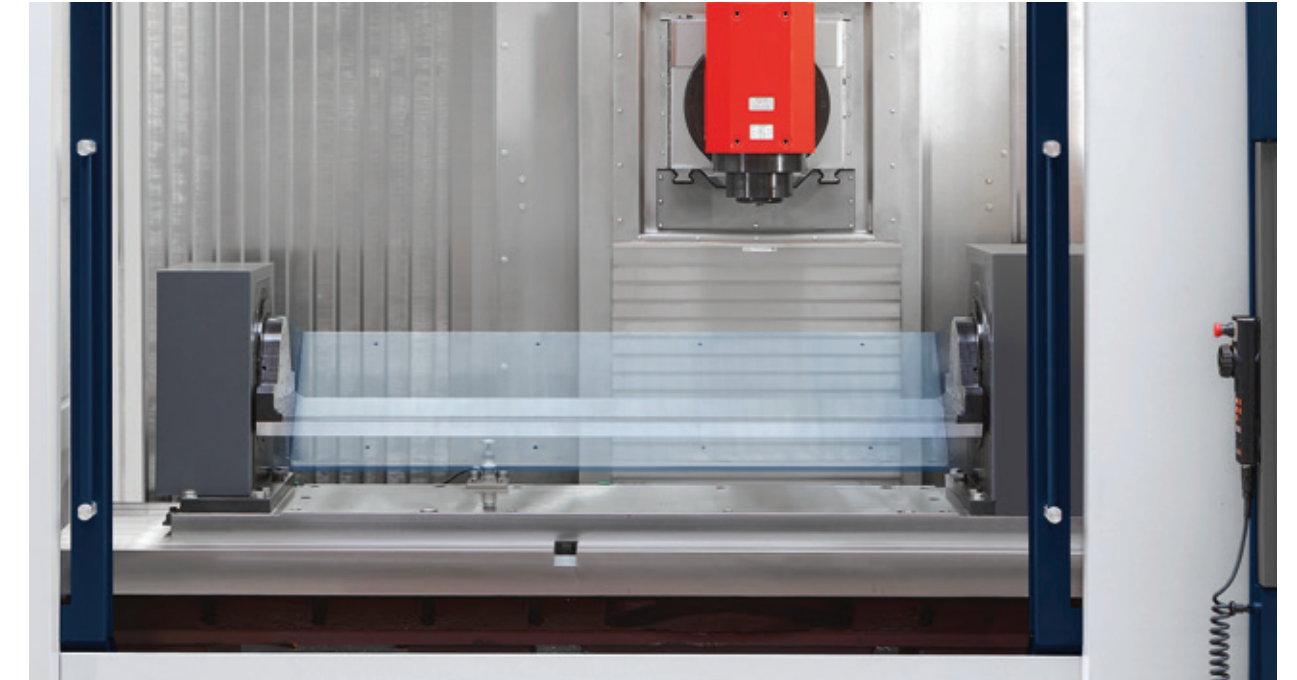

LARGE WORK AREA

Thanks to the large work area it is possible to customize the machine with numerous options, such as partition for shuttle operation, rotary table, tailstock, etc.

NETWORKS ARE CREATED INDIVIDUALLY – OUR SOLUTIONS AS WELL

Staying in touch is important not only among human beings. Persons, machines and the whole production environment must also be connected perfectly and safely in order to ensure efficient procedures during the production process. With EMCONNECT, the machine is optimally equipped for this purpose. The optional EMCONNECT Digital Services offer innovative online services for optimized machine operation. The user has always the control of the machine status. The automatic notification in case of malfunctions or standstill of the machine as well as the extended capabilities for remote maintenance, minimise downtimes.

Integration into control

EMCONNECT offers several possibilities of operation according to different situations. For quick access, apps may be used simultaneously in the side panel of controlling. In this way, you can always look at your familiar numerical control, the well-known centrepiece of the machine.

An innovative concept

These powerful apps may be used independently from the control, while in the background the machine is busy in the production process. With only one click, you can change at any moment between numerical control and EMCONNECT. This is possible with the help of an innovative and ergonomic control panel, equipped with a modern 22" multi-touch display, an industrial PC with associated keyboard and HMI hotkeys.



The control panel as central platform

With EMCONNECT, the control panel of the machine becomes the central platform for the access to all the operative functions. The user gets every type of support from the apps, which directly provide all the necessary applications, data and documents. In this way, EMCONNECT makes an important contribution to a highly efficient processing at the machine.



Comprehensive connectivity options

With the remote support, the web browser and the remote desktop, there are numerous connectivity options, even beyond the direct production environment. With the help of the integrated remote support, it is easily possible to carry out the remote diagnosis and remote maintenance. The optionally available OPC UA interface enables data exchange with the IT system environment and interaction with other machines for automation at shop floor level.

EMCONNECT HIGHLIGHTS AND FUNCTIONS

- / Fully connected**
Connection to all applications via remote control of the office computer and the web browser
- / Structured**
Clear monitoring of the machine state and the production data
- / Customized**
Open platform for modular integration of customer-specific applications
- / Compatible**
Interface for seamless integration into the operating environment
- / User-friendly**
Intuitive and production-optimized touch operation data
- / Future-proof**
Continuous extensions as well as easy updates and upgrades

Standard Apps

Control	Dashboard
Machine Data	System
Remote Desktop	Web Browser
Remote Support	Settings
Cutting Calculator	Calculator
Notes	Service
Documents	EMCO TechSheet
GD&T	File Import
Shopfloor Data	Thread Reference
	Tricalc

Optional

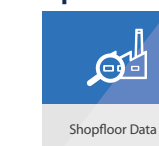

MACHINE LAYOUT

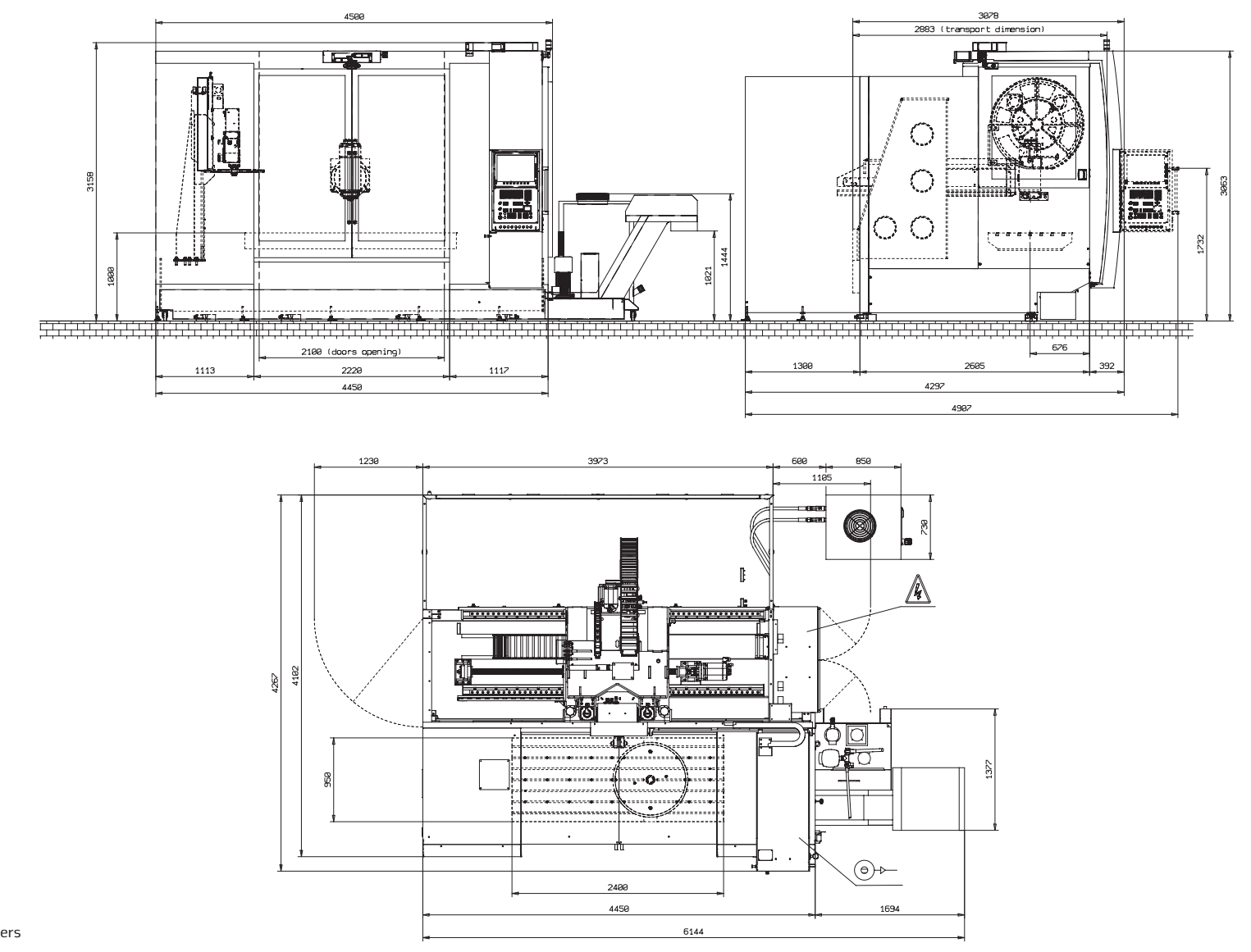

Indications in millimeters

WORK AREA

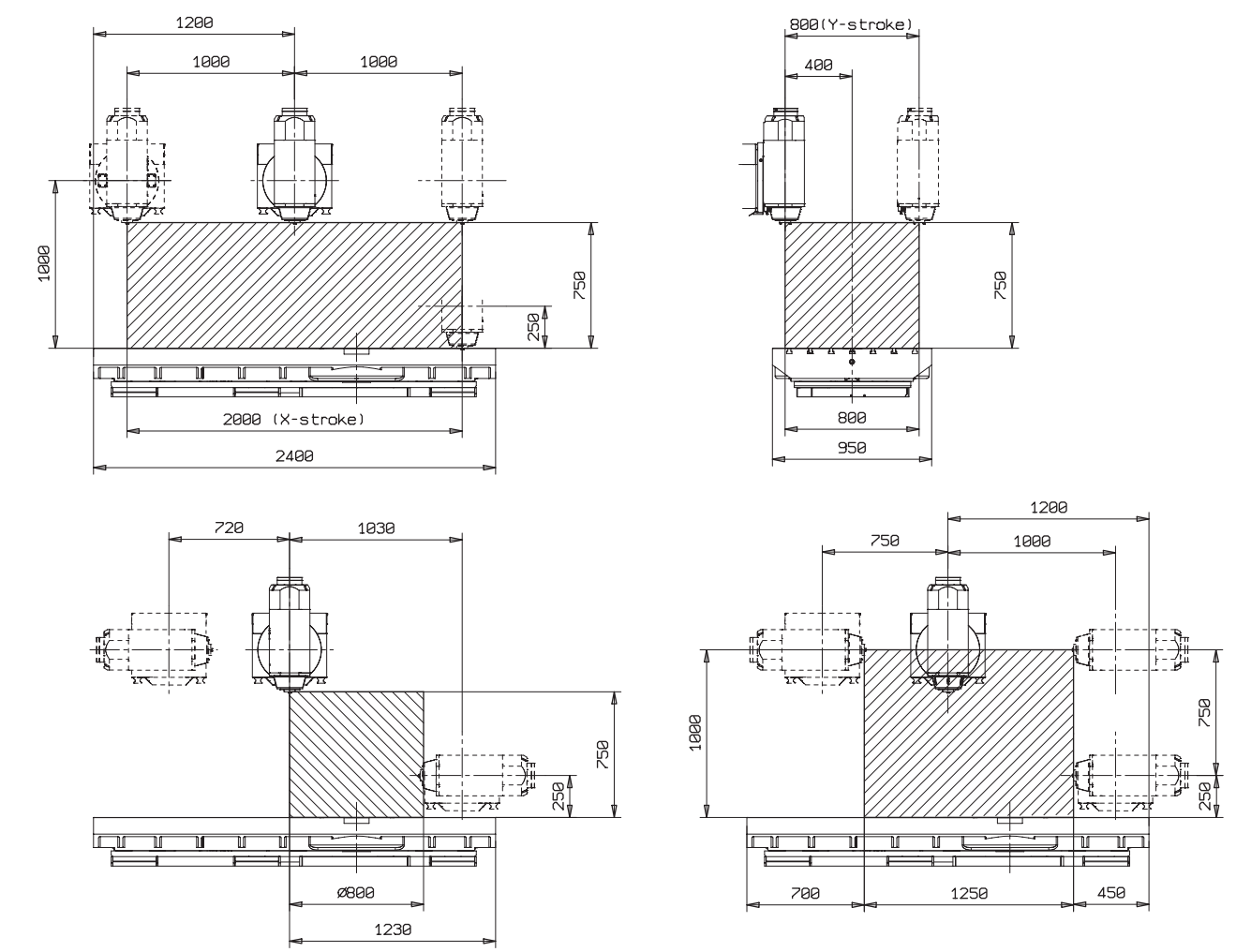

Indications in millimeters

POWER AND TORQUE

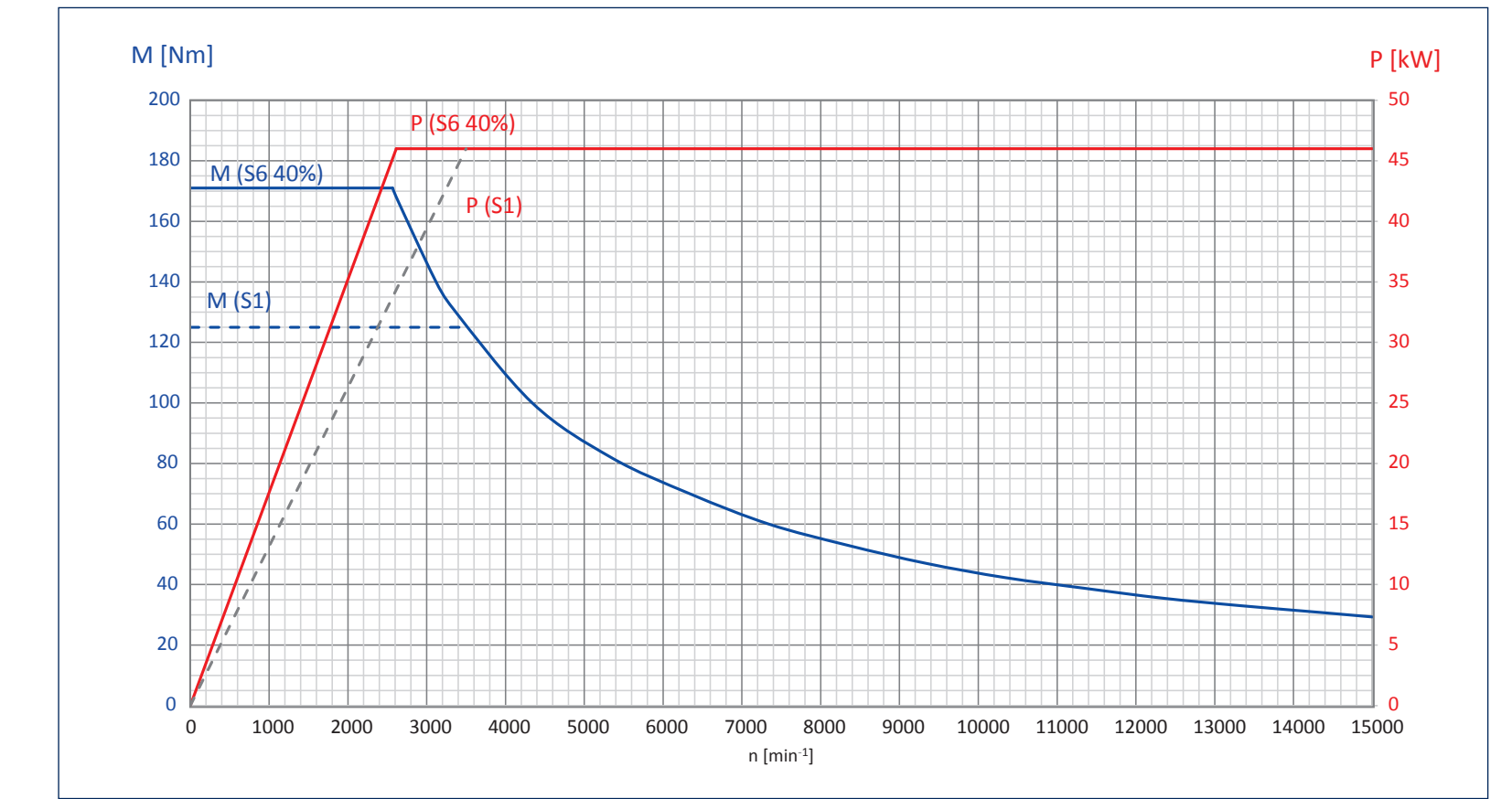

TECHNICAL DATA

Travel

Travel in X-axis	2000 mm
Travel in Y-axis	800 mm
Travel in Z-axis	750 mm
Minimum distance spindle nose – table	0 mm
Maximum distance spindle nose – table	750 mm

Table

Length	2400 mm
Width	950 mm
Slot size	18 mm
Number of slots	7
Slot spacing	125 mm
Maximum table load (equally distributed)	2200 kg

Rotary table

Diameter	800 mm
Maximum table load	1500 kg
Drive	Torque Motor

Main spindle ISO / BT

Speed range	50 - 15000 rpm
Torque	125 Nm (S1), 170 Nm (S6-40%)
Spindle power	46 kW
Tool taper DIN 69871 / option	ISO 40 / BT 40

Main Spindle HSK A63 (optional)

Speed range	50 - 18000 rpm
Torque	125 Nm (S1), 170 Nm (S6-40%)
Spindle power	46 kW
Tool taper	HSK-A63

Tool magazine

Number of tool stations (options)	40 (60)
Option tool magazine left/right	40/40 or 60/40
Changeover principle	S - Arm
Tool management	random
Max. tool diameter	75 mm
Max. tool diameter (without adjacent tools)	125 mm
Max. tool length	380 mm
Max. tool weight	8 kg
Max. tool magazine weight	160 kg

Feed drives

X / Y / Z rapid motion speeds	50 / 50 / 50 m/min
Acceleration in X-/ Y- /Z-axis	2 / 4 / 4 m/s ²

Coolant system

Coolant pressure	2 bar
Outlet at spindle	4 nozzles

Pneumatic supply

Supply pressure	6 bar
-----------------	-------

Lubrication

Guides	Automatic central lubrication with grease
Ballscrews	Automatic central lubrication with grease

Dimensions/weight

Overall height	3160 mm
Dimensions w x d	6144 x 4297 mm
Total weight of machine	22000 kg

beyond standard /

EMCO GmbH / Salzburger Str. 80 / 5400 Hallein-Taxach / Austria / T +43 6245891-0 / F +43 624586965 / info@emco.at

www.emco-world.com