

EMCO

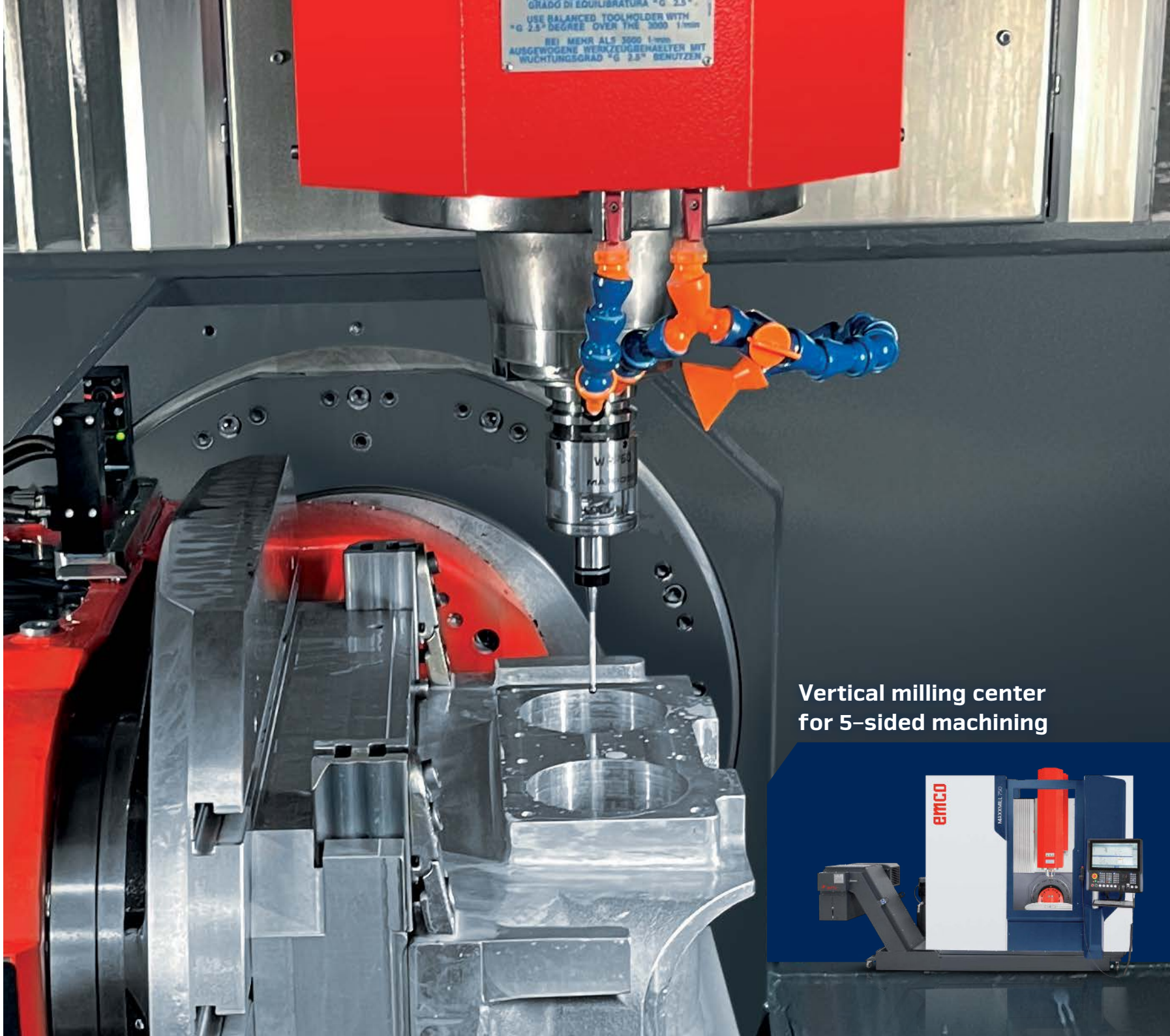

GRADO DI EQUILIBRATURA "G 2.5"
USE BALANCED TOOLHOLDER WITH
"G 2.5" DEGREE OVER THE 3000 1/min
BEI MEHR ALS 3000 1/min
AUSGEWEGNE WERKZEUGBEHALTER MIT
WUCHTUNGSGRAD "G 2.5" BENUTZEN

Vertical milling center
for 5-sided machining



MAXXMILL 630 / 750

COMPACT VERTICAL MILLING CENTER

The CNC vertical milling center MAXXMILL 630 is capable to mill parts with an edge size of 445 x 445 x 290 mm in just one operation in an efficient and precise way. Its compact design in cast iron and welded steel guarantees the maximum in rigidity and thermosymmetry. Short power flows assure the highest precision and an excellent surface quality of the workpiece.

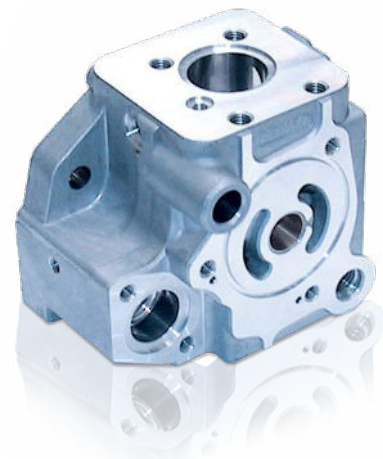

Housing
(Cast steel)

1 MACHINE BASE

/ The machine base consists of welded steel construction, the X-Y slide and the Z-axis are cast iron

2 TOOL MAGAZINE

/ Tool changer with 30 tool stations
/ Chain magazine with 60/90 tool stations optional available

3 SPINDLE

/ Mechanical spindle direct drive: 12000 rpm
/ Motor spindle: 15000 rpm

4 WORK TABLE

/ Solid swivel rotary with a clamping area: 630 x 500 mm
/ Optional with counter bearing for increased stability



5 OPERATING PANEL

/ Available with Heidenhain or Siemens control technology
/ 90° swivelling operating panel
/ Process assistant EMCONNECT available for Siemens



SINUMERIK ONE INCL. SHOPMILL



HEIDENHAIN TNC 620

6 CHIP REMOVAL

/ The chip removal can be handled by an optional available hinge tape chip conveyer
/ Machine room rinsing and table rinsing as option available

COMPACT VERTICAL MILLING CENTER

The CNC vertical milling center MAXXMILL 750 is capable to mill parts with an edge size of 530 x 530 x 417 mm in just one operation in an efficient and precise way. Its compact design in cast iron and welded steel guarantees the maximum in rigidity and thermosymmetry. Short power flows assure the highest precision and an excellent surface quality of the workpiece. At the MAXXMILL 750, with its long Y-axis, large linear guides and the ability to machine workpieces up to a maximum weight of 300 kg (500 kg), optimum conditions were created for the production.



Screw support
(Steel)

1 MACHINE BASE

/ The machine base consists of welded steel construction, the X-Y slide and the Z-axis are cast iron

2 TOOL MAGAZINE

/ Tool changer with 30 tool stations
/ Tool changer with 40 or 60/90 tool stations as option available

3 SPINDLE

/ Mechanical spindle direct drive: 12000 rpm
/ Motor spindle: 15000 rpm

4 WORK TABLE

/ Solid swivel rotary with a clamping area: 750 x 600 mm
/ Optional with counter bearing for increased stability



5 OPERATING PANEL

/ Available with Heidenhain or Siemens control technology
/ 90° swivelling operating panel
/ Process assistant EMCONNECT available for Siemens



SINUMERIK ONE INCL. SHOPMILL

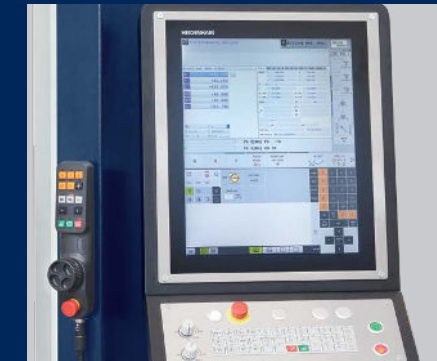

HEIDENHAIN TNC 620

6 CHIP REMOVAL

/ The chip removal can be handled by an optional available hinge tape chip conveyer
/ Machine room rinsing and table rinsing as option available

TECHNICAL HIGHLIGHTS



Direct encoders are already installed in the B-axis as standard. This guarantees a higher processing accuracy even in the standard version.

Furthermore, the MAXXMILL series has been designed in such a way that the large working space remains as clean as possible thanks to an intelligent chip disposal solution.

HIGHLIGHTS

- / 5-sided machining in a single set-up
- / Highest thermostability
- / Swivel range B-axis $\pm 100^\circ$
- / Top machining precision
- / Modern moving column concept
- / Massive swivelling rotary table 750 x 600 mm 630 x 500 mm provides high stability and precision
- / Compact machine design
- / Cutting-edge control technology from Siemens or Heidenhain
- / Process Assistant EMCONNECT available for Siemens
- / Extensive options such as water-cooled motor spindle with 15000 rpm
- / Optimal chip removal
- / Attractive price-performance ratio
- / MAXXMILL 630 now also available in a 3-axis version
- / Made in the Heart of Europe

APPLICATION AREAS

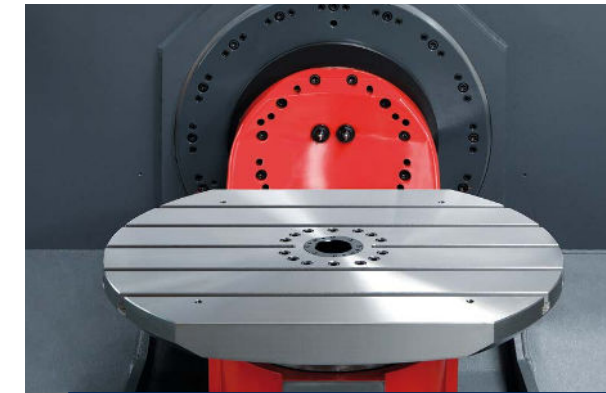
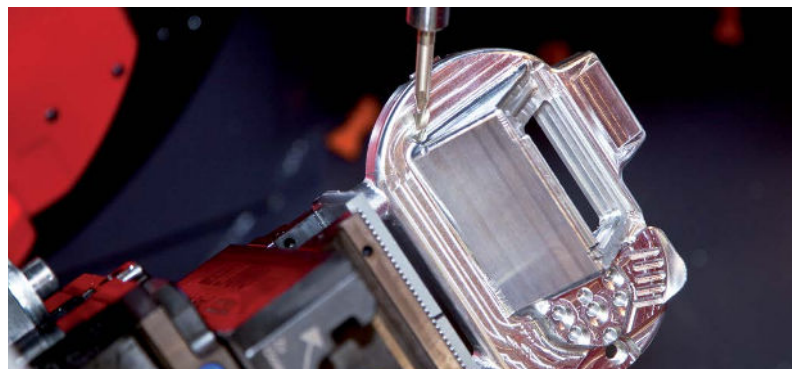
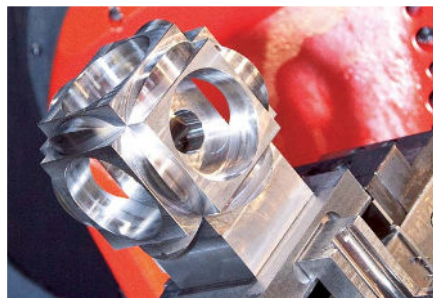

SWIVEL-ROTARY TABLE

The swivel-rotary table has a large clamping area of 630 x 500 mm resp. 750 x 600 mm and can bear loads of up to 500 kg (MM750 with counter support). This makes it possible to simply machine workpieces with an edge size of 445 x 445 x 290 mm or 530 x 530 x 417 mm. The special shape of the table allows the spindle nose to move closer to the table center.

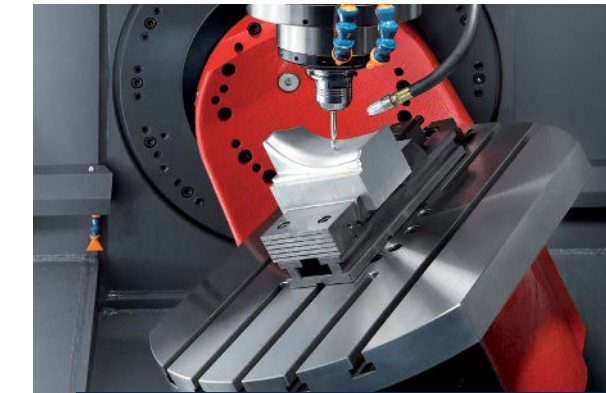

SWIVEL RANGE

With a swivel range of $\pm 100^\circ$, the B-axis provides a larger work area than most products from other manufacturers. The C-axis can be infinitely rotated by 360° .

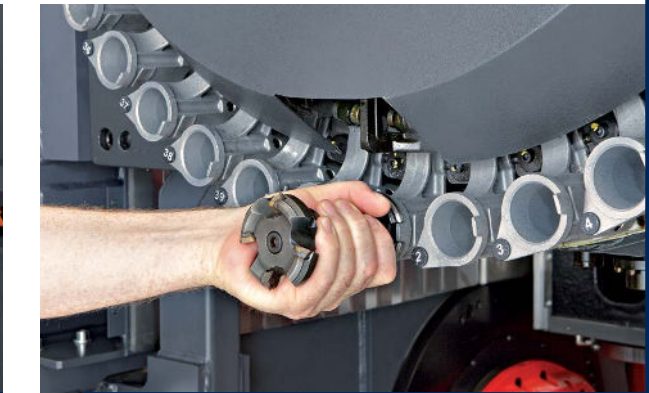

TOOL CHANGER

The tool changer of the MAXXMILL 630 is a drum magazine for 30 tools (60/90 tool stations as option). For MAXXMILL 750, a drum tool magazine with 40 is standard, 60/90 tool stations are available optionally. The tools are managed according to the variable tool station coding principle (random), which means that tools are always deposited in the first free magazine station for time reasons.



DIRECT DRIVE

The direct drive on the Z-axis stands for highest accuracy. In case of power failure a special brake prevents the falling of the axis.

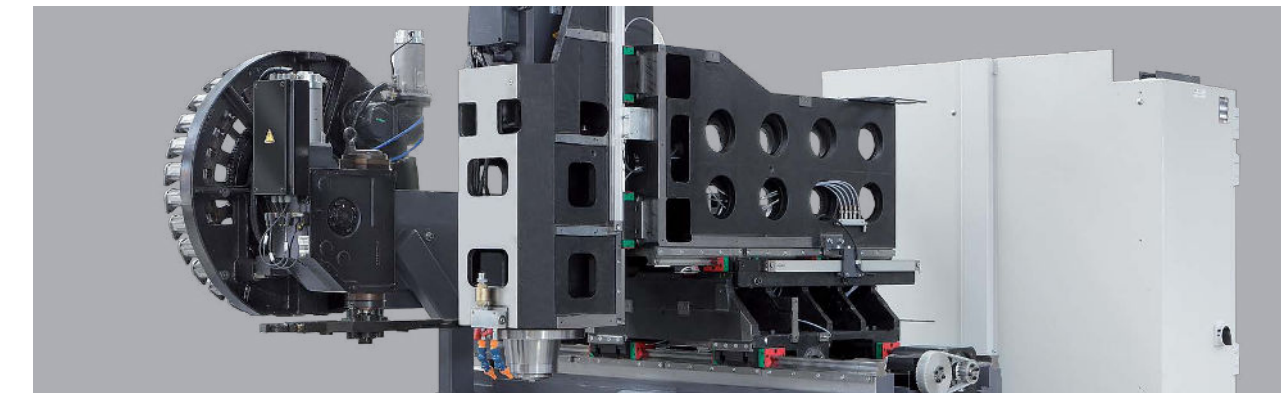

MASSIVE STRUCTURE

The guides, slides and the machining head are made of cast iron to ensure maximum stability and best finish of the workpiece. The stable components are optimized by FEM analysis.

NETWORKS ARE CREATED INDIVIDUALLY – OUR SOLUTIONS AS WELL

Staying in touch is not only important for people. Staff, machines and the production environment must also be securely networked with each other to ensure an efficient production process. With EMCONNECT, the machine is optimally equipped for this. In addition, EMCONNECT Digital Services provides innovative online services to optimise machine operation. The machine data form the basis for a wide range of applications. In this way, the user has the status of the machine available at any time and in any place.

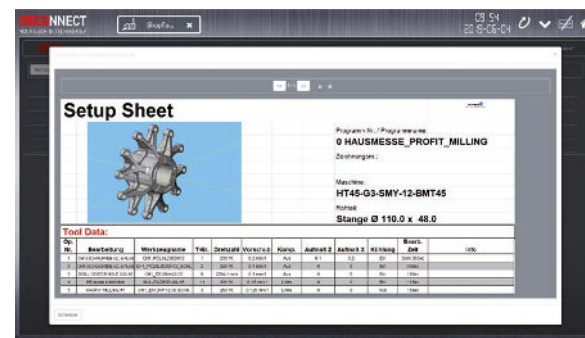

Control panel as central platform

With EMCONNECT, the machine control panel becomes a central platform with access to all necessary applications, data and documents. Remote Support, Web Browser and Remote Desktop offer a wide range of connection options, even outside the direct production environment. The optional OPC UA interface allows data exchange with the IT system environment and interaction with other machines for shop floor automation. In this way, EMCONNECT makes an important contribution to highly efficient machine operation.



Innovative online services

With EMCONNECT Digital Services, all interested users have online access to the current status and evaluations of the machine. Automatic notification in the event of malfunctions or machine stoppages and extended diagnostic options for remote maintenance reduce downtimes and machine downtime to a minimum. Integrated maintenance management supports predictive maintenance based on machine utilisation. Thanks to the continuous development of online services, new functions are always available.

Integration into the control

EMCONNECT offers options for situation-dependent operation. Apps can also be used in parallel with the control system. With optimal integration into the NC control system, EMCONNECT complements the NC control with powerful functions for modern control generations (SIEMENS, HEIDENHAIN). The familiar vision of the machine NC control is maintained at all times.

An innovative concept

These powerful apps may be used independently from the control, while in the background the machine is busy in the production process. With only one click, you can change at any moment between numerical control and EMCONNECT. This is possible with the help of an innovative and ergonomic control panel, equipped with a modern 22" multi-touch display, an industrial PC with associated keyboard and HMI hotkeys.

EMCONNECT HIGHLIGHTS AND FUNCTIONS

- Fully networked**
Remote access to office computers, web browsers and online services with all applications and users connected
- Compatible**
Interface for seamless integration into the operating environment
- Structured**
Clear monitoring of the machine state and the production data
- User-friendly**
Intuitive and production-optimized touch operation
- Customized**
Open platform for modular integration of customer-specific applications
- Future-proof**
Continuous extensions as well as easy updates and upgrades

Standard-Apps

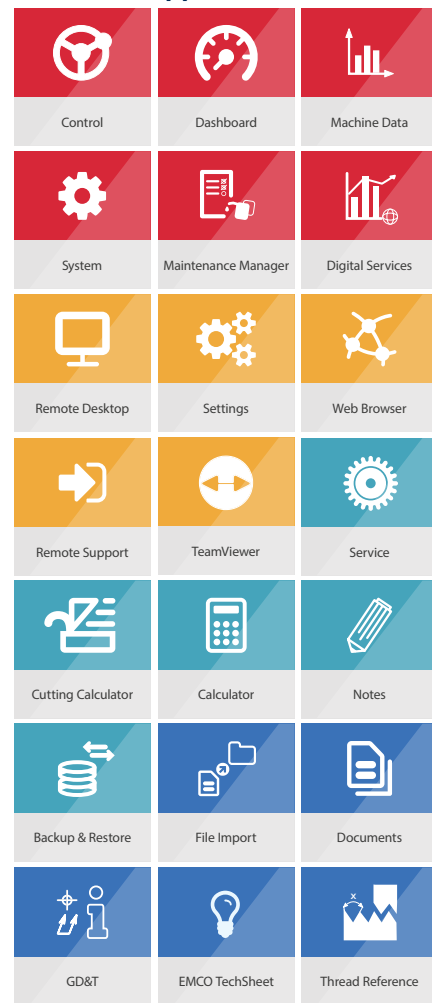

Optional

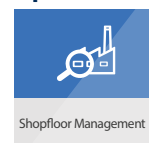

INSTALLATION PLAN AND MACHINE LAYOUT

MAXXMILL 630

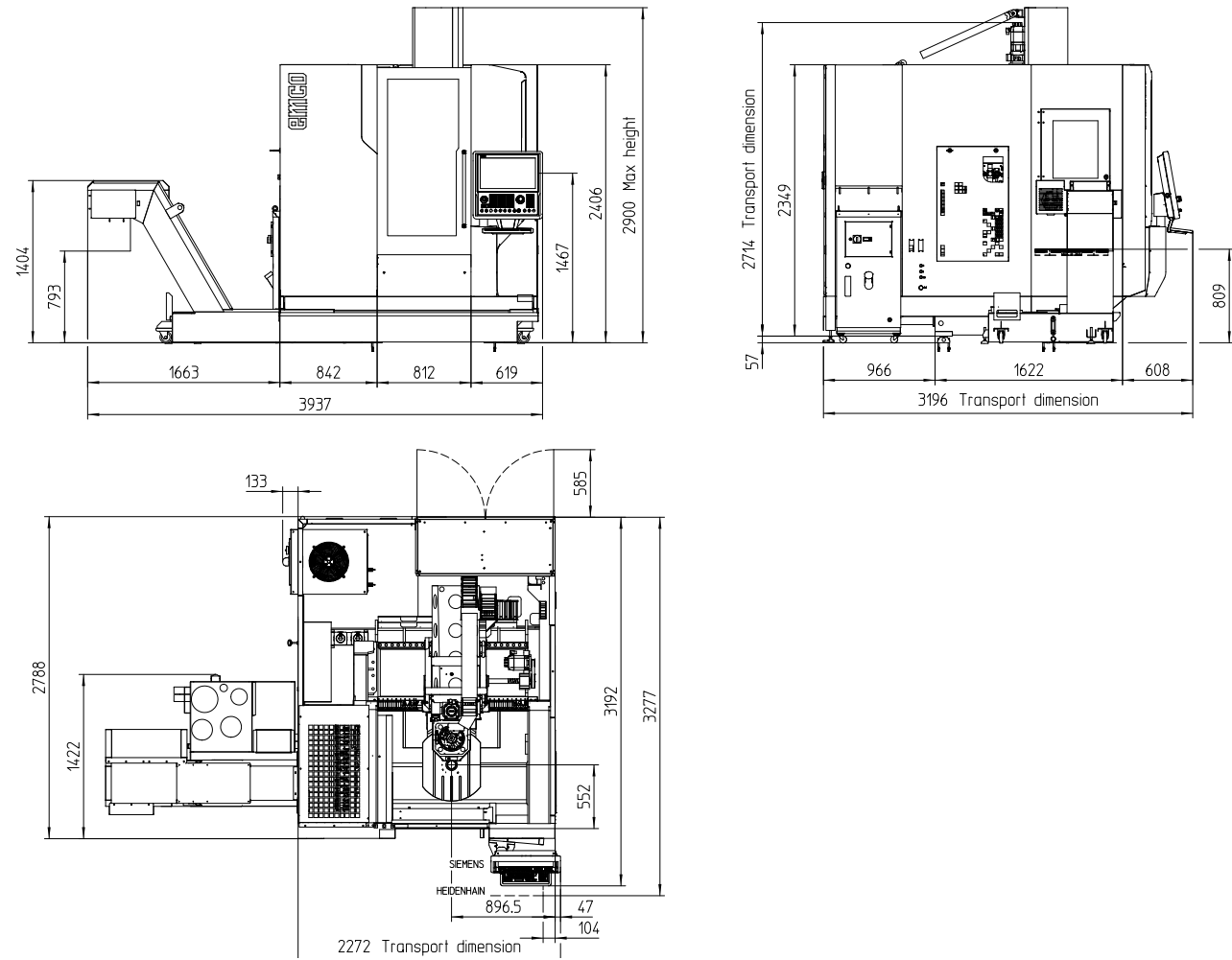

Indications in millimetres

INSTALLATION PLAN AND MACHINE LAYOUT

MAXXMILL 750

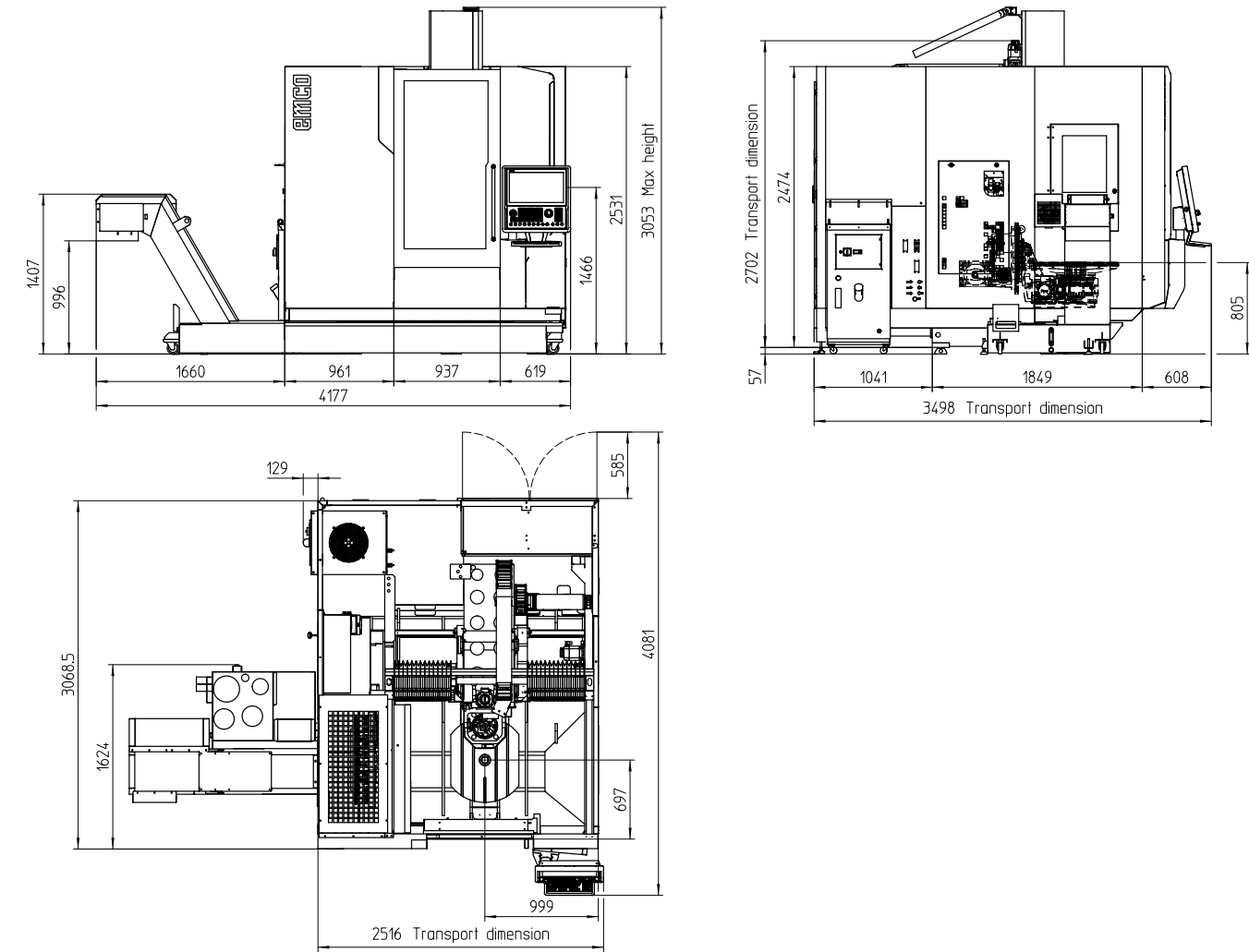

Indications in millimetres

WORK AREA

MAXXMILL 630

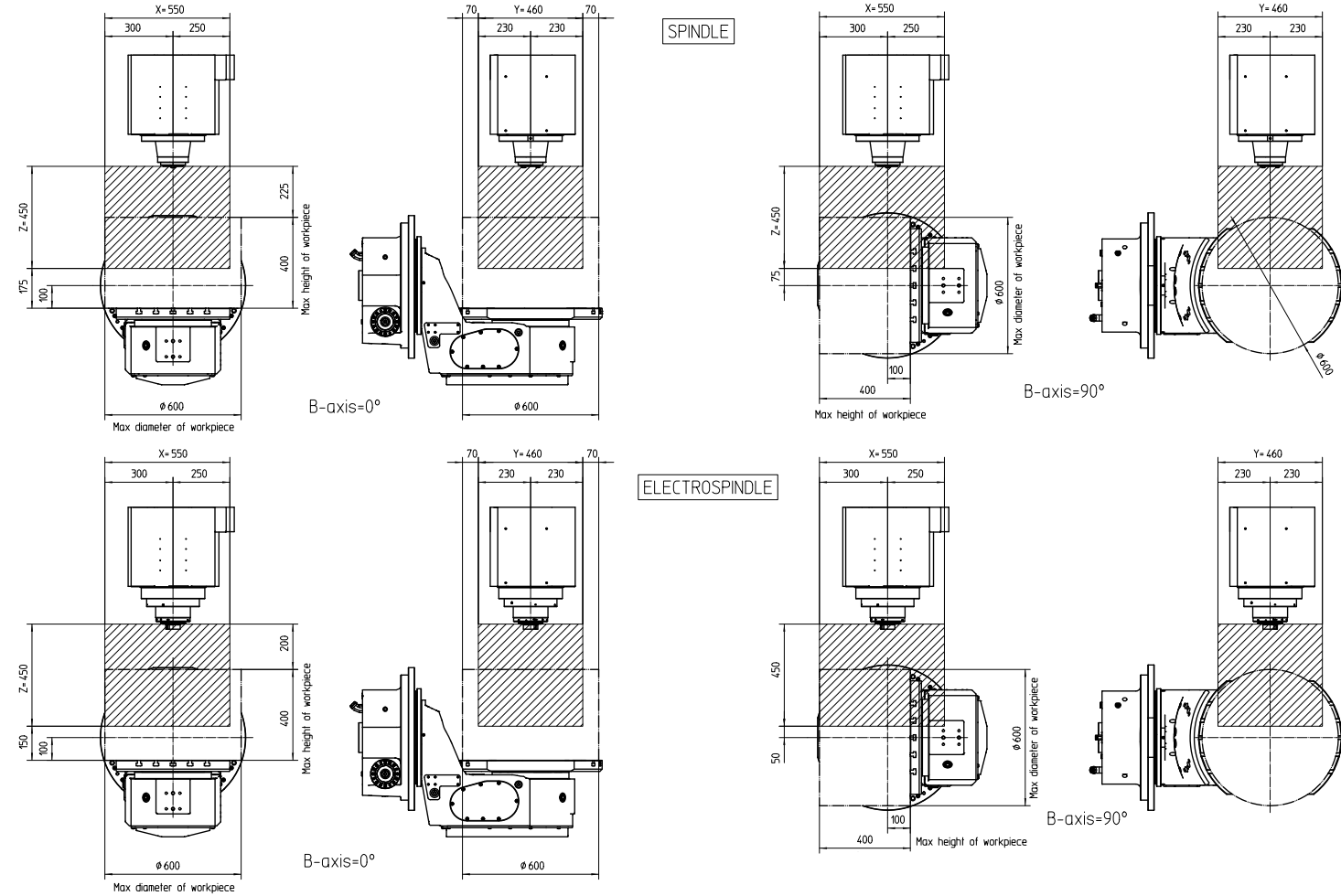

Indications in millimetres

work area max. dimension of the workpiece

WORK AREA

MAXXMILL 750

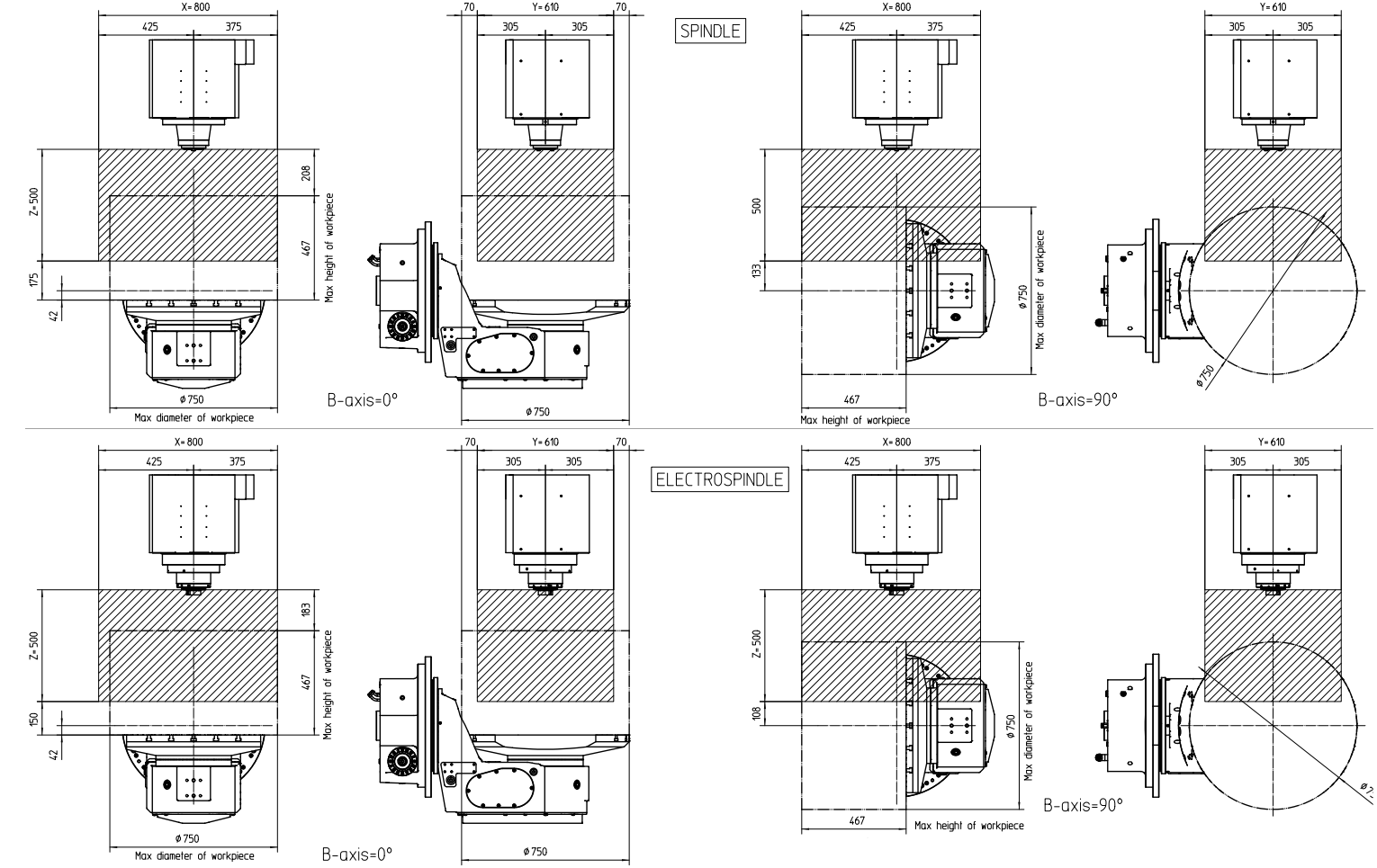

Indications in millimetres

work area max. dimension of the workpiece

TECHNICAL DATA

Travel and tolerances	MM 630	MM 750
Travel in X	500+50 mm	750+50 mm
Travel in Y	460 mm	610 mm
Corsa asse Z	450 mm	500 mm
Distance spindle nose – table (min. – max. / mechanical spindle)	175 / 625 mm	175 / 675 mm
Distance spindle nose – table (min. – max. / motor spindle)	150 / 600 mm	150 / 650 mm
Swivel range B-axis	+/- 100°	+/- 100°
Range of rotation C-axis (rotary table)	0 – 360°	0 – 360°
Positioning accuracy P according to VDI 3441 *	10 µm	10 µm
Positioning repeatability Ps according to VDI 3441 *	4 µm	4 µm
Positioning accuracy B axis (tilting – with motor encoder)	5 sec	5 sec
Positioning accuracy C axis (table – with motor encoder)	15 sec	15 sec

Feed

Rapid motion speed X–Y–Z axis	30 m/min	30 m/min
Max. rotational speed B axis	16 rpm	25 rpm
Max. rotational speed C axis	25 rpm	25 rpm
Max. feed force X axis	5000 N	5000 N
Max. feed force Y axis	5000 N	5000 N
Max. feed force Z axis	5000 N	5000 N
Max. acceleration X–Y–Z axis	3 m/s ²	3 m/s ²

Tilting table

Clamping area	630 x 500 mm	750 x 600 mm
Table–floor distance	809 mm	805 mm
Slot number	5	5
Distance between two T-slots	75 mm	100 mm
Groove wide	14 mm	14 mm
Max. workpiece weight (equally distributed)	200 kg	300 kg
Max. permissible workpiece weight with counter bearing	400 kg	500 kg

Main spindle (mechanical spindle)

Speed range	50 – 12000 rpm	50 – 12000 rpm
Max. spindle torque	100 Nm	100 Nm
Max. spindle power	15kW	15kW
Tool taper	ISO 40	ISO 40
Drive	direct drive	direct drive

Main spindle (motor spindle 15000 rpm)

	MM 630	MM 750
Speed range	50 – 15000 rpm	50 – 15000 rpm
Max. spindle torque	100 Nm	100 Nm
Max. spindle power	20 kW	20 kW
Tool taper	ISO 40 (HSK-A63)	ISO 40 (HSK-A63)

Tool magazine

Number of tool stations	30 (60/90)	30 (40/60/90)
Tool changing type	double arm gripper	double arm gripper
Tool management	random	random
Tool changing time (tool-tool)	2 sec	2 sec
Max. tool diameter	80 mm	80 mm
Max. tool diameter (without neighbouring tools)	125 mm	125 mm
Max. tool length	250 mm	250 mm
Max. tool weight	8 kg	8 kg
Total tool weight supported by the magazine	100 kg	100 kg

Coolant tank

Tank capacity	200 l	250 l
Standard pump pressure	2 bar	2 bar
Max. capacity at 2 bar	40 l/min	40 l/min

Pneumatic supply

Min. pressure supply	6 bar	6 bar
Min. capacity required	250 l/min	250 l/min

Lubrication

Spindle	Grease	Grease
Linear roller ways	Grease	Grease
Ball screws	Grease	Grease

Dimensions

Total height	2900 mm	3060 mm
Dimensions L x D without chip conveyer	2630 x 3200 mm	2840 x 3500 mm
Weight	6500 kg	7900 kg

* Measurement of the values at 22°C and machine fixed to the floor. Machine with linear scales – distance compensation with laser and Motor value sensors in the rotation axis.

beyond standard /

EMCO GmbH / Salzburger Str. 80 / 5400 Hallein-Taxach / Austria / T +43 6245 891-0 / F +43 6245 86965 / info.at@emco-world.com

www.emco-world.com