

# Top<sup>®</sup>

**AUTOMAZIONI**

BAR FEEDERS & AUTOMATIONS



**NO MORE REASONS  
TO WAIT**



**ARM IS ONE OF TOP AUTOMAZIONI'S  
ROBOTIC SOLUTIONS**

**INTEGRATED TOWER STORAGE FOR  
THE LOADING/UNLOADING OF  
COMPONENTS**

**CONFIGURABLE WITH ALL  
NUMERICALLY CONTROLLED  
MACHINES SUCH AS LATHES,  
MACHINING CENTERS,  
GRINDERS, AND OTHERS  
EQUIPMENT**

**i4.0**



## LAYOUT AND INSTALLATION

ARM is available in several versions (SL - Left, SC - Central, SR - Right) to adapt to any CNC machine tool and related workshop environment.

The onboard position of the Fanuc always leaves the intervention area on the CNC machine free, when the ARM is not in use. This aspect allows regular and comfortable operation on the HMI panel, convenient set up of the CNC machine and quick equipment's checks.

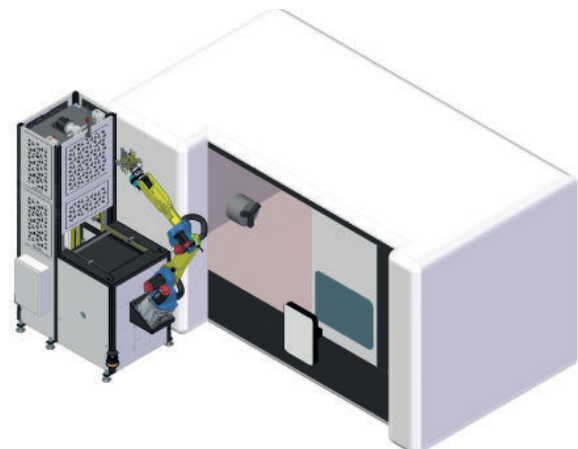



Scan the QR CODE to watch the video



ARM

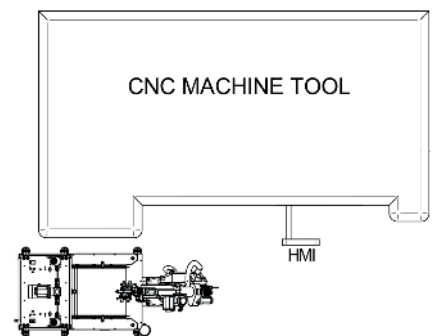
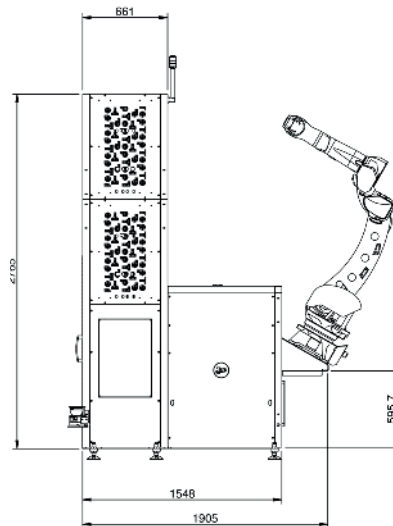
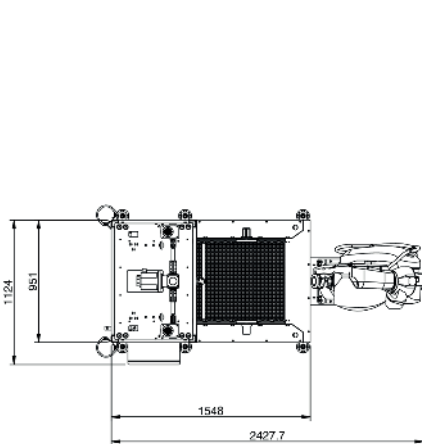



## ROBOT FEATURES

- Fanuc M-20iD25
- Payload 25 kg
- Max reach 2.000mm, center tool point
- Max speed (J6) 720°/s
- Repeatability +/-0,02mm
- Wrist protection class IP67
- Weight 250 Kg



## CONTROL UNIT

- Controller R30iB-PLUS
- Intuitive programming
- Friendly interface
- Fanuc collaborative functions
- Touchscreen
- Machine utilization statistics
- Intelligent maintenance prediction software
- Eccentric loading and unloading mode
- Park positioning function
- Tower full handling



## GRIPPER FEATURES (TAILORED ON THE PROJECT)

- 2-fingers gripper for rectangular shapes
- 3-fingers gripper for round shapes
- 2-fingers gripper for long shafts
- Customized gripper for specific shapes
- Air blow system
- Quick change system for gripper
- Low air pressure detection

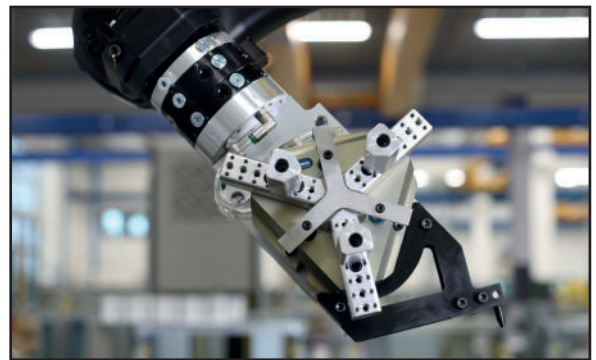

## ADDITIONAL WORKING STATIONS

- Parts unloading on box/cage/belt
- Parts positioning on measuring station
- Other tailored customers operations available

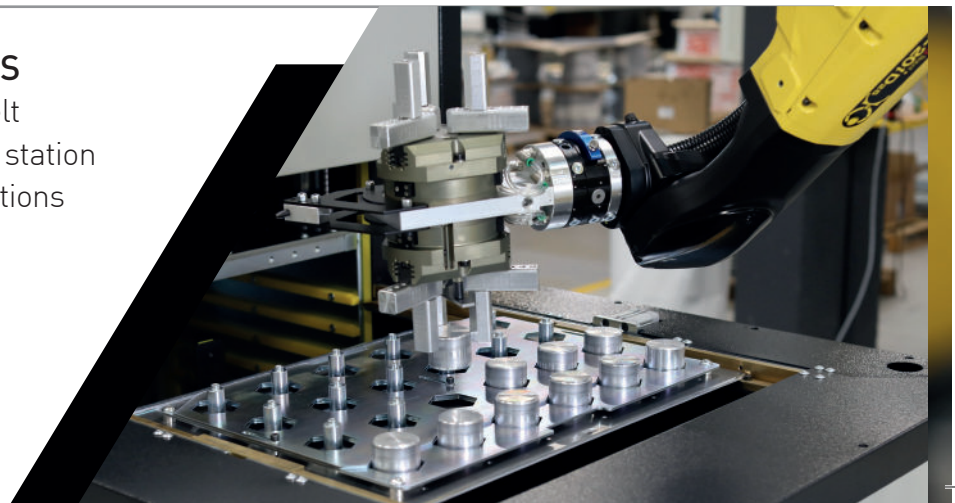

### INTEGRATED TOWER PARTS STORAGE SYSTEM

- Payload 1.000 kilos
- Stack of max 24 trays (depending on the workpieces shape and dimension)

Max part/stack height (mm)	42	92	142	192
Trays (nr)	24	12	8	6

- Tray dimensions 600x400mm
- Max load each tray 45 kilos
- Metal galvanized structure and trays for long lasting
- Trays quick locking system



### SAFETY FEATURES

- Fanuc Dual Check Safety System integrated with laser scanner
- Pneumatic or servo-motor driven CNC machine door opener with integrated safety circuit if predisposed



### CONNECTION PREDISPOSITION

- Teleservice predisposition
- Predisposition for Industry 4.0 connection

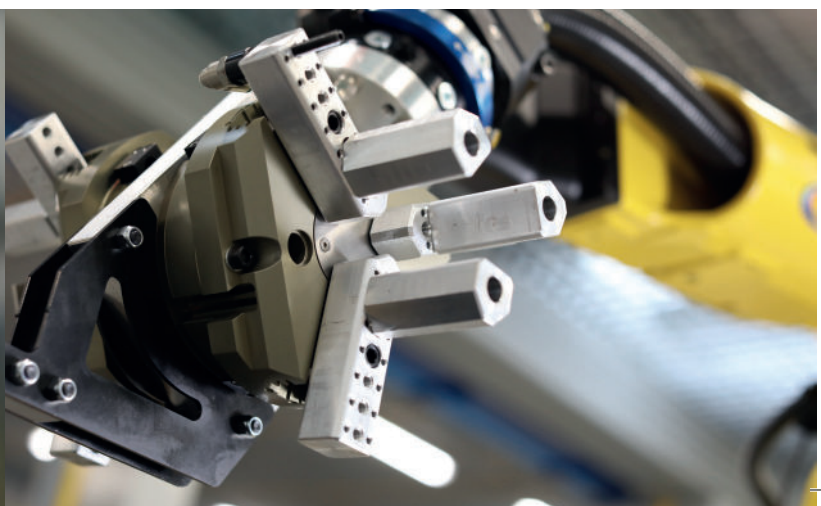



HOW TO FIND US ▶  
scan QR code



TOP AUTOMAZIONI S.R.L.

Via Torrianese, 62  
47824 Poggio Torriana (RN)

Tel. +39 0541 688248

Fax +39 0541 688168

topautomazioni@topautomazioni.com

www.topautomazioni.com

